

ADA & CE Compliant VoIP Emergency Phones with Multicast Paging

The **1600-IP Series** of ADA Compliant VoIP Emergency Phones are designed to provide quick and reliable handsfree communication for SIP VoIP phone systems with PoE and also allows for standard paging via multicast. All **1600-IP Series** phones meet ADA requirements for elevator or emergency telephones, and can be programmed from any touch tone phone or PC on the same LAN or remotely using a static IP address. The phones can dial up to 5 programmable emergency numbers. In addition, the **E-1600-20-IP**, **E-1600-22-IP**, **E-1600-52-IP** and **E-1600-TP2IPEWP** feature a second "INFO" button that will dial up to 5 non-emergency numbers. Two amp relay contacts are provided for strobe light, camera, door/gate control, etc.

The **1600-IP Series** phones can be programmed to automatically deliver a digital announcement to identify the location of the emergency call. Alternatively, a DTMF touch tone code may also be delivered. A "Call Connected" LED can be initiated manually or automatically. All programming parameters, including phone numbers and location numbers, are stored in non-volatile memory. All units are PoE powered.

For outdoor installations where the unit is exposed to precipitation or condensation, select **1600-IP Series** phones are available with Enhanced Weather Protection (**EWP**). EWP products are designed to meet IP66 standards and may feature foam rubber gaskets, sealed connections, gel-filled butt connectors, as well as potted circuit boards with internally sealed, field-adjustable trim pots and DIP switches for easy onsite programming. For more information go to www.vikingelectronics.com/ewp

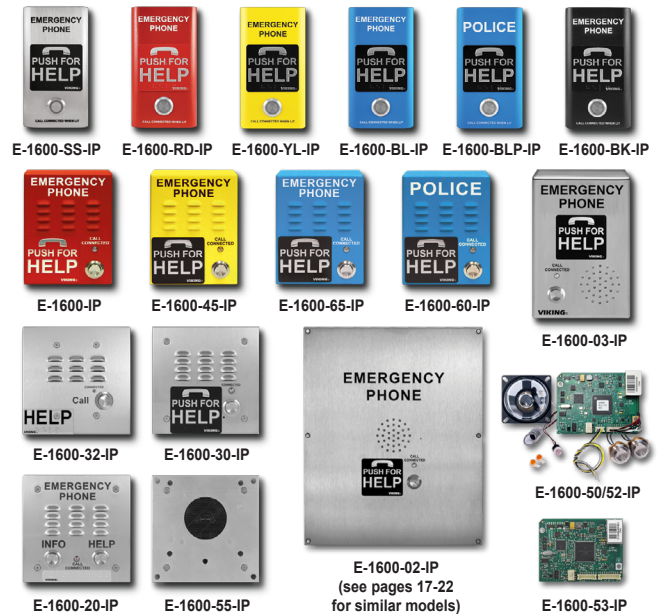

⚠ Installation requires a Network Administrator / IT Technician

Features

- Parallel programming, firmware updates, and polling with **Viking Device Manager**
- 2 Amp relay contacts for door/gate or **SL-2** Strobe Light control
- SIP compliant (see page 2 for more information)
- ASME A17.1 code compliant when used with the model **LV-1K** Line Verification Panel
- Outbound Proxy, Authentication ID, Peer to Peer, VLAN Tagging
- PoE powered (class 1, <4 Watts)
- Paging prioritization
- SIP endpoint or multicast group member
- Compatible with Polycom multicast paging
- SIP/Multicast: SIP page, SIP page and zoned multicast receive
- VoIP eliminates the need for "Push to Talk" mode
- Network downloadable firmware
- Meets ADA requirements for Emergency Phones:
 - Automatically lights the Red "Call Connected" LED
 - Transmits a unique location I.D. code or voice announcement
 - Grade 2 Braille label for the visually impaired
- Non-volatile digital voice announcer with 28 seconds of voice memory
- Marine grade 316 stainless steel prevents corrosion on the stainless steel models
- Laser etched graphics on stainless steel models
- Dials up to 5 emergency numbers
- **E-1600-20-IP**, **E-1600-22-IP**, **E-1600-52-IP**, and **E-1600-TP2IPEWP** dial up to 5 non-emergency "INFO" numbers
- Optional Enhanced Weather Protection (EWP), EWP products are designed to meet IP66 Ingress Protection Rating, go to: www.vikingelectronics.com/ewp
- Hangs up on busy signal, time-out or touch tone command
- Extended temperature range (-40°F to 140°F)
- Available in 42" tower phone model **E-1600-BLTIPEWP**
- Optional **LV-1K** Line Verification Panel
- Optional **PB-100** Polling System
- Optional **SL-2** or **BLK-4-EWP** Strobe Light Kit
- Optional **E-1600A-MK-GNP** Pedestal Mounting Kit
- Optional **PB-1** Panic Button Kit

Applications

- Elevators
- Parking ramps/lots
- Emergency pool phones
- ATM machines
- Medical centers
- Silent hold-up alarm dialer with an optional **PB-1** Panic Button Kit
- Area of refuge locations
- Lobbies
- Entryways
- Campus emergency stations
- Stadiums
- Convention centers
- Public access areas

** Americans with Disabilities Act of 1992 contains federal regulations regarding elevator telephones (Public Law 101-336).*

www.VikingElectronics.com

Specifications

- Power:** PoE class 1 (<4 Watts)
- Maximum Sound Pressure:** 95 dB SPL @ 1m
- Dimensions:** See Installation and Specifications
- Operating Temperature:** -40°F to 140°F (-40° C to 60° C)
- Humidity - Standard Products:** 5% to 95% non-condensing
- Humidity - EWP Products:** Up to 100%
- Audio Codecs:** G711u, G711a, G722
- Network Compliance:** IEEE 802.3 af PoE, SIP 2.0 RFC3261, 100BASE-TX with auto cross over
- Regulatory Compliance:** CE, FCC Part 15 and Canada ICES-003 Class A
- Connections:** (1) RJ45 10/100 Base-T, (3) gel-filled butt connectors

VoIP SIP System Compatibility

See the **Viking VoIP SIP System Compatibility List** for compatibility and vendor specific detailed configuration instructions. To download the PDF file, do one of the following:

SCAN:



CLICK: [Viking VoIP SIP System Compatibility List](#).

COPY: <https://vikingelectronics.com/wp-content/uploads/VoIP-Compatibility944.pdf>

Important: *Exclusion from this list does not mean incompatibility, it only means that compatibility has not been verified. If you have questions, please call Viking Electronics at 715-386-8861.*

Definitions

Client: A computer or device that makes use of a server. As an example, the client might request a particular file from the server.

DHCP: Dynamic Host Configuration Protocol. In this procedure the network server or router takes note of a client's MAC address and assigns an IP address to allow the client to communicate with other devices on the network.

DNS Server: A DNS (Domain Name System) server translates domain names (ie: www.vikingelectronics.com) into an IP address.

Ethernet: Ethernet is the most commonly used [LAN](#) technology. An Ethernet Local Area Network typically uses twisted pair wires to achieve transmission speeds up to 1Gbps.

Host: A computer or device connected to a network.

Host Name: A host name is a label assigned to a device connected to a computer network that is used to identify the device in various forms of network communication.

Hosts File: A file stored in a computer that lists host names and their corresponding IP addresses with the purpose of mapping addresses to hosts or vice versa.

Internet: A worldwide system of computer networks running on [IP](#) protocol which can be accessed by individual computers or networks.

IP: Internet Protocol is the set of communications conventions that govern the way computers communicate on networks and on the [Internet](#).

IP Address: This is the address that uniquely identifies a host on a network.

LAN: Local Area Network. A LAN is a network connecting computers and other devices within an office or building.

Lease: The amount of time a [DHCP](#) server reserves an address it has assigned. If the address isn't used by the host for a period of time, the lease can expire and the address can be assigned to another host.

MAC Address: MAC stands for Media Access Control. A MAC address, also called a hardware address or physical address, is a unique address assigned to a device at the factory. It resides in the device's memory and is used by routers to send network traffic to the correct IP address. You can find the MAC address of your **1600-IP Series** phone printed on a white label on the top surface of the PoE LAN port.

Router: A device that forwards data from one network to another. In order to send information to the right location, routers look at [IP Address](#), [MAC Address](#) and [Subnet Mask](#).

RTP: Real-Time Transport Protocol is an Internet protocol standard that specifies a way for programs to manage the real-time transmission of multimedia data over either unicast or multicast network services.

Server: A computer or device that fulfills requests from a client. This could involve the server sending a particular file requested by the client.

Session Initiation Protocol (SIP): Is a signaling communications protocol, widely used for controlling multimedia communication sessions such as voice and video calls over Internet Protocol ([IP](#)) networks. The protocol defines the messages that are sent between endpoints, which govern establishment, termination and other essential elements of a call.

Static IP Address: A static IP Address has been assigned manually and is permanent until it is manually removed. It is not subject to the [Lease](#) limitations of a [Dynamic IP Address](#) assigned by the [DHCP Server](#). The **IP Device** has DHCP enabled by default. If it is not able to obtain an IP address from the network server or router, it falls back to a last known IP address. If the network settings in the **IP Device** are reset (See Programming Section F) and the **IP Device** is not able to obtain an IP address from the network server or router, the **IP Device** forgets the last known IP address and falls back to a default static IP address of: **192.168.154.1**

Subnet: A portion of a network that shares a common address component. On TCP/IP networks, subnets are defined as all devices whose IP addresses have the same prefix. For example, all devices with [IP addresses](#) that start with 100.100.100. would be part of the same subnet. Dividing a network into subnets is useful for both security and performance reasons. IP networks are divided using a subnet mask.

TCP/IP: Transmission Control Protocol/Internet Protocol is the suite of communications protocols used to connect hosts on the Internet. TCP/IP uses several protocols, the two main ones being TCP and IP. TCP/IP is built into the UNIX operating system and is used by the Internet, making it the de facto standard for transmitting data over networks.

TISP: Telephone Internet Service Provider

WAN: Wide Area Network. A WAN is a network comprising a large geographical area like a state or country. The largest WAN is the [Internet](#).

Overview of Chassis and Mounting Options

Note: When European CE compliance is required, mount open board models within a metal enclosure.



Model: E-1600-1P
HxWxD: 5.25 x 4.0 x 2.0
Mounting: Surface mount
Description: 16 gauge steel with textured red powder paint



Model: E-1600-20-IP
HxWxD: 5.0 x 5.0 x 2.25
Mounting: Flush mount with included rough-in box (will not fit in a double gang box), or surface mount with a **VE-5x5**
Description: Two button, marine grade 316 stainless steel with #4 brushed finish, T-10 Torx Security Screws



Model: E-1600-45-IP
HxWxD: 5.25 x 4.0 x 2.0
Mounting: Surface mount
Description: 16 gauge steel with textured yellow powder paint



Model: E-1600-22-IP
HxWxD: 5.0 x 5.0 x 2.25
Mounting: Flush mount in a standard double gang electrical box or surface mount with a **VE-5x5**
Description: Two button, marine grade 316 stainless steel with #4 brushed finish, T-10 Torx Security Screws



Model: E-1600-60-IP
HxWxD: 5.25 x 4.0 x 2.0
Mounting: Surface mount
Description: 16 gauge steel with textured blue powder paint and "POLICE" verbiage



Model: E-1600-30-IP
HxWxD: 5.0 x 5.0 x 2.25
Mounting: Flush mount with included rough-in box (will not fit in a double gang box), or surface mount with a **VE-5x5**
Description: Marine grade 316 stainless steel with #4 brushed finish, T-10 Torx Security Screws



Model: E-1600-65-IP
HxWxD: 5.25 x 4.0 x 2.0
Mounting: Surface mount
Description: 16 gauge steel with textured blue powder paint



Model: E-1600-32-IP
HxWxD: 5.0 x 5.0 x 2.25
Mounting: Flush mount in a standard double gang electrical box or surface mount with a **VE-5x5**
Description: Marine grade 316 stainless steel with #4 brushed finish, T-10 Torx Security Screws



Model: E-1600-03-IP
HxWxD: 7.22 x 5.36 x 1.55
Mounting: Surface mount
Description: Marine grade 316 stainless steel with #4 brushed finish



Model: E-1600-50-IP
Description: Single button 1600-IP parts kit without chassis



Model: E-1600-52-IP
Description: Two button 1600-IP parts kit without chassis

Model: E-1600-53-IP
Description: 1600-IP board (PCB) only kit. Can be used to convert any analog Viking 1600A-Series phone to a VoIP version



Model: E-1600-54-IP
Description: A universal VoIP emergency phone retrofit kit for replacing an existing "behind the elevator panel" emergency phone



Model: E-1600-02-IP
HxWxD: 13.0 x 10.5 x 2.0
Mounting: Flush mount
Description: Marine grade 316 stainless steel with #4 brushed finish

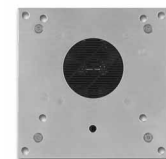

Model: E-1600-55-IP
HxWxD: 5.0 x 5.0 x 2.0
Description: Universal emergency phone kit to install behind elevator panels or when a custom panel is used

Overview of Chassis and Mounting Options

Note: When European CE compliance is required, mount open board models within a metal enclosure.



Model: E-1600-BK-IP
HxWxD: 5.75 x 3.08 x 1.05
Mounting: Surface mount
Description: 304 stainless steel with fine textured black powder paint



Model: E-1600-RD-IP
HxWxD: 5.75 x 3.08 x 1.05
Mounting: Surface mount
Description: 304 stainless steel with fine textured red powder paint



Model: E-1600-BL-IP
HxWxD: 5.75 x 3.08 x 1.05
Mounting: Surface mount
Description: 304 stainless steel with fine textured blue powder paint



Model: E-1600-SS-IP
HxWxD: 5.75 x 3.08 x 1.05
Mounting: Surface mount
Description: Marine grade 316 stainless steel with a #4 brushed finish



Model: E-1600-BLP-IP
HxWxD: 5.75 x 3.08 x 1.05
Mounting: Surface mount
Description: 304 stainless steel with fine textured blue powder paint and "POLICE" verbiage



Model: E-1600-YL-IP
HxWxD: 5.75 x 3.08 x 1.05
Mounting: Surface mount
Description: 304 stainless steel with fine textured yellow powder paint



Model: E-1600-GT-IPEWP
HxWxD: 12.0 x 10.0 x 2.0
Mounting: Flush mount
Description: Direct physical replacement for GAI-TRONICS Red Alert Model 397-700



Model: E-1600-TP-IPEWP
HxWxD: 11.75 x 9.5 x 2.0
Mounting: Flush mount
Description: Direct physical replacement for Talk-A-Phone models ETP-400V or VoIP-500



Model: E-1600-TP2IPEWP
HxWxD: 11.75 x 9.5 x 2.0
Mounting: Flush mount
Description: Direct physical replacement for Talk-A-Phone models ETP-400DV or VoIP-500D



Model: E-1600-RT-IPEWP
HxWxD: 11.938 x 8.281 x 2.0
Mounting: Flush mount
Description: Flush Mount to RAMTEL PLC MINI Columns, towers, wall mounts, 926 and 906 boxes and pedestals



Model: E-1600-RTMIPEWP
HxWxD: 8.5 x 6.5 x 2.0
Mounting: Flush mount
Description: Flush Mount to RAMTEL MINI Columns, towers, wall mounts, 924 and 904 boxes and pedestals



Model: E-1600-912-IP(EWP)
HxWxD: 11.225 x 67.08 x 2.0
Mounting: Mounts in Viking Model VE-9X12 Series Outdoor Enclosures
Description: Marine grade 316 stainless steel with #4 brushed finish

Features Overview

Rear (PCB) View of E-1600-IP Series Emergency Phone

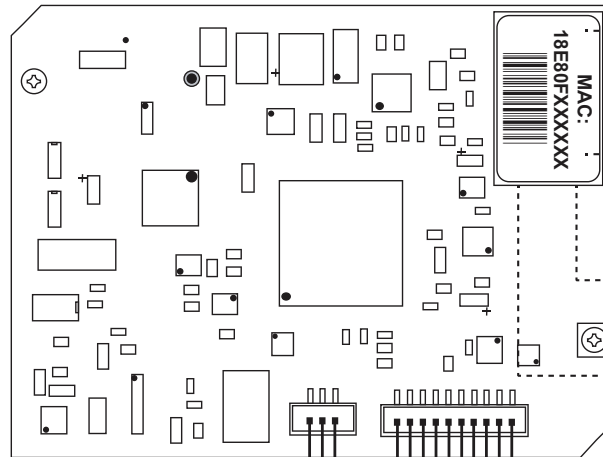

- PoE LAN Port 10/100, PoE Class 1 (<4 Watts):** Connect to your LAN via RJ45 plug and CAT5 or greater twisted pair wire.
- MAC Address Label:** The MAC address is a unique 12 digit number used by routers to send network traffic to the correct IP address.
- Yellow Network Status LED:** Lights steady to indicate power and data link. Blinks to indicate network activity.
- Green Unit Status LED**



Viking model LV-1K shown (not included)

Connect to Optional Strobe Light, LV-1K, etc.

OR



Viking model SL-2 shown (not included)

Optional 2 Amp Relay Output Contacts
(2A@30VDC / 250VAC max)

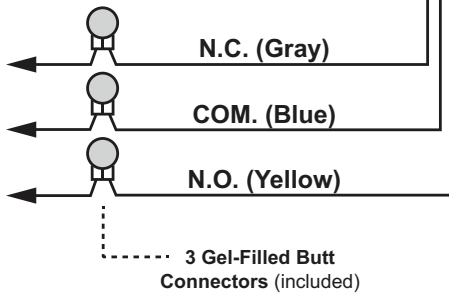

- Black LED
- + Red
- Black Help Switch
- Black
- Red Info Switch (optional)
- Red
- Yellow Speaker
- Yellow
- Black Microphone
- + Red

Note: The gel-filled (water-tight) butt connectors are designed for insulation displacement on 19-26 gauge wire with a maximum insulation of 0.082 inches. Cut off stripped wire ends before terminating.

Installation and Specifications

The following sections show specifications and installation instructions for the different chassis in the 1600-IP Series.

⚠ IMPORTANT: Electronic devices are susceptible to lightning and power station electrical surges from both the AC outlet and the telephone line. It is recommended that a surge protector be installed to protect against such surges.

E-1600-IP / E-1600-45-IP / E-1600-60-IP / E-1600-65-IP

Dimensions: 5.25" x 4.0" x 2.0" (133 mm x 102 mm x 51 mm)

Shipping Weight: 2.5 lbs (1.13 kg)

Material: Cold rolled steel

Finish: E-1600-IP: Red powder paint
 E-1600-45-IP: Yellow powder paint
 E-1600-60-IP: Blue powder paint with "POLICE" verbiage
 E-1600-65-IP: Blue powder paint

Connections: Gel-filled butt connectors

Mounting: Surface mount to walls, posts, single gang boxes or 4" x 4" electrical junction boxes or recess mount in elevator phone boxes. Attach mounting plate in desired location. Attach wires then fasten cover to mounting plate with set screw.

Optional Enhanced Weather Protection (EWP) Available: EWP products are designed to meet IP66 standards and may feature foam rubber gaskets, sealed connections, gel-filled butt connectors, as well as potted circuit boards with internally sealed, field-adjustable trim pots and DIP switches for easy onsite programming. For more information go to www.vikingelectronics.com/ewp

Note: For greater weather resistance, apply a bead of clear silicon caulking around the top edge and sides of the chassis.

Optional Gooseneck Pedestal Mounting Kit: The E-1600A-MK-GNP Mounting Kit allows you to mount the E-1600A, E-1600-40A, E-1600-45A, E-1600-60A or E-1600-65A to any Viking Gooseneck Pedestal.

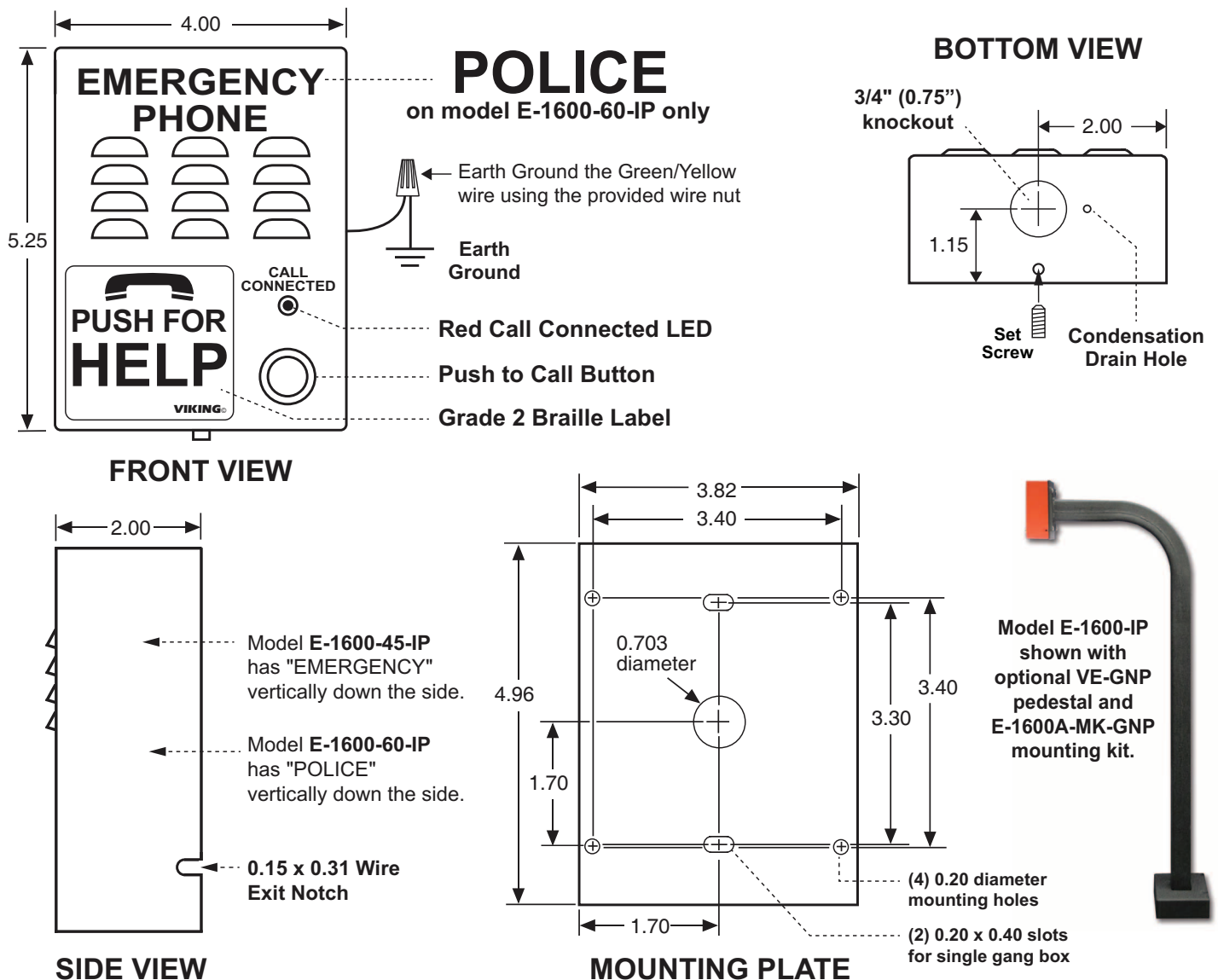

E-1600-SS-IP / E-1600-RD-IP / E-1600-YL-IP / E-1600-BL-IP / E-1600-BLP-IP / E-1600-BK-IP

Dimensions: 5.75" x 3.08" x 1.05" (146 mm x 78 mm x 27 mm)

Shipping Weight: 2.5 lbs (1.3 kg)

Material / Finish E-1600-SS-IP only: Marine grade 316 stainless steel with a #4 brushed finish

Material: 304 stainless steel

- Finish:**
- E-1600-RD-IP:** Red fine texture powder paint
 - E-1600-YL-IP:** Yellow fine texture powder paint
 - E-1600-BL-IP:** Blue fine texture powder paint
 - E-1600-BLP-IP:** Blue fine texture powder paint with "POLICE" verbiage
 - E-1600-BK-IP:** Black fine texture powder paint

Connections: Gel-filled butt connectors

Mounting: Surface mount to walls, posts or single gang electrical boxes. Attach the mounting plate in desired location and connect the wires. Then, secure the phone to the mounting plate with provided 8-32 set screws.

Optional Enhanced Weather Protection (EWP) Available: EWP products are designed to meet IP66 standards and may feature foam rubber gaskets, sealed connections, gel-filled butt connectors, as well as potted circuit boards with internally sealed, field-adjustable trim pots and DIP switches for easy onsite programming. For more information go to www.vikingelectronics.com/ewp

Note: For greater weather resistance, apply a bead of clear silicon caulking around the top edge and sides of the chassis.

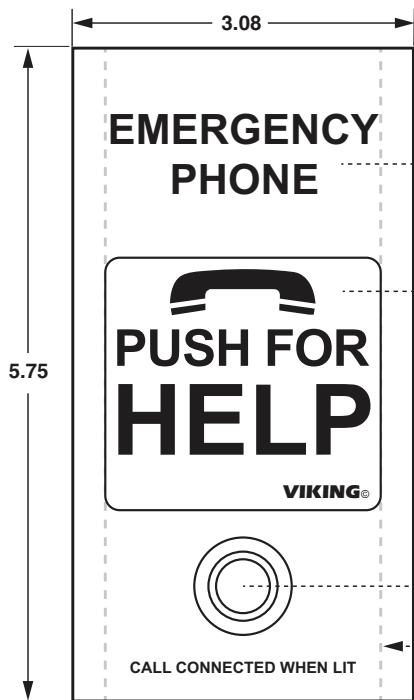

FRONT VIEW

POLICE
(model E-1600-BLP-IP only)

Grade 2 Braille Label

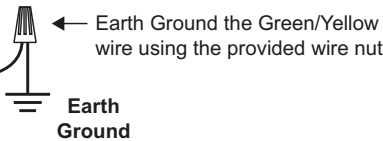

Push to Call button with red backlit Call Connected LED

0.313 Radius

BOTTOM VIEW

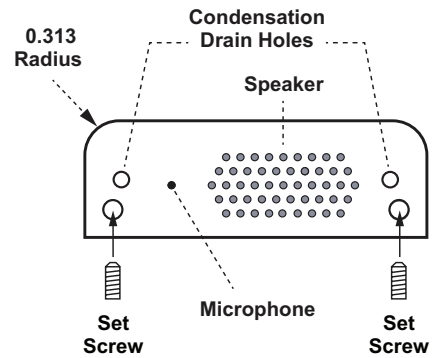

SIDE VIEW

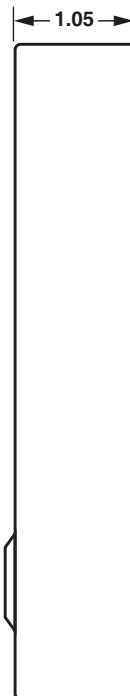

MOUNTING PLATE DIMENSIONS

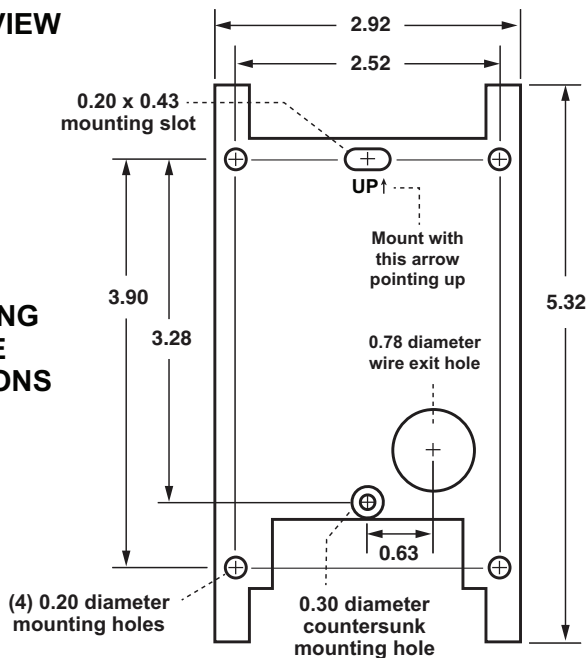

E-1600-02-IP

Dimensions: 13" x 10.5" x 2" (330mm x 267mm x 51mm)

Shipping Weight: 7 lbs (3.18 kg)

Connections: Gel-filled butt connectors

Material: Marine grade 316 stainless steel with a #4 brushed finish

Mounting: Flush mount in elevator cabs, ATMs, stairwells, hallways, etc.

Suggested Hardware: (6) #8 x 3/4 flat head phillips sheet metal type A screws (not included)

Optional Enhanced Weather Protection (EWP) Available: EWP products are designed to meet IP66 standards and may feature foam rubber gaskets, sealed connections, gel-filled butt connectors, as well as potted circuit boards with internally sealed, field-adjustable trim pots and DIP switches for easy onsite programming. For more information go to www.vikingelectronics.com/ewp

Note: When mounting outside to rough or uneven surfaces (brick, stucco, etc.) apply a bead of clear silicone caulking around the top edge and sides of faceplate.

Note: When European CE compliance is required, mount onto a metal enclosure.

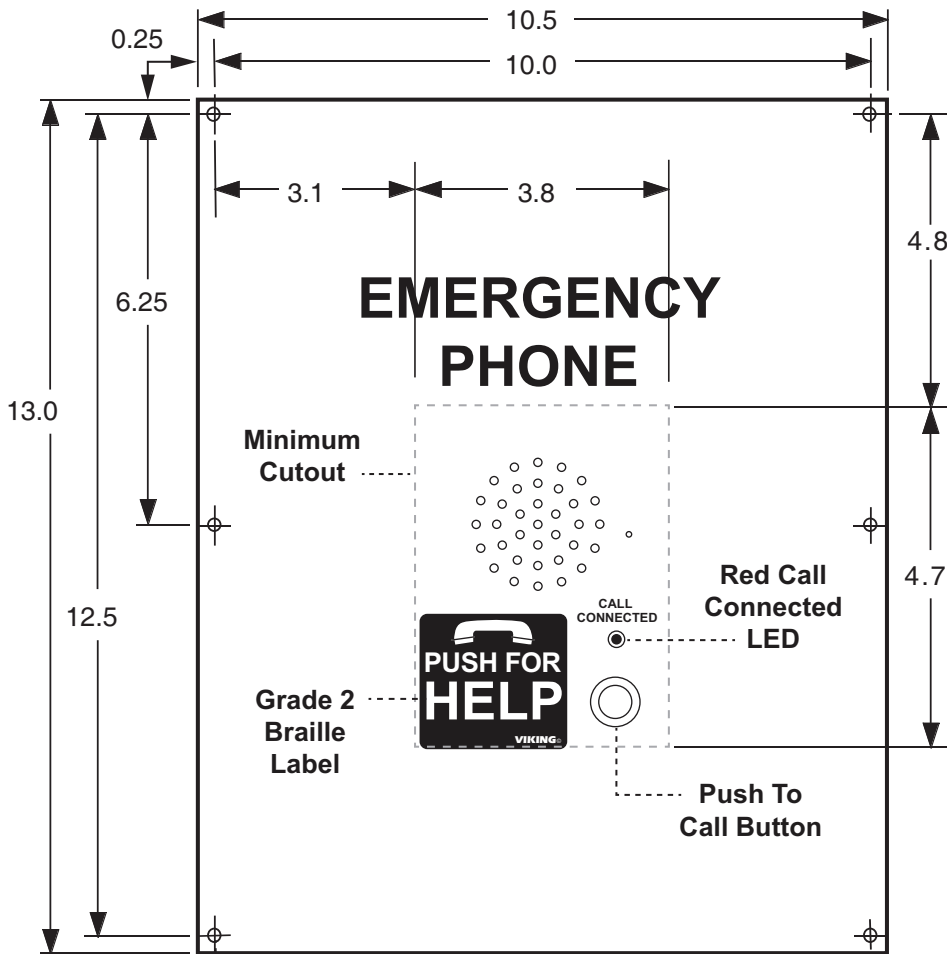

(6) 0.188 diameter countersunk holes

FRONT VIEW

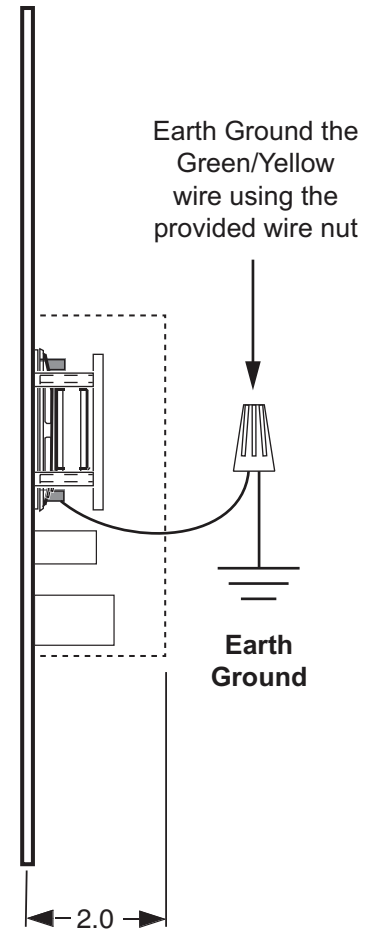

SIDE VIEW

Dimensions: 7.22" x 5.36" x 1.55" (183mm x 149mm x 39mm)

Material: Marine grade 316 stainless steel with a #4 brushed finish

Shipping Weight: 3.0 lbs (1.36 kg)

Connections: Gel-filled butt connectors

Mounting: Surface mount to walls, posts, single gang boxes, double gang boxes or 4" x 4" electrical junction boxes or recess mount in elevator phone boxes. Attach mounting plate in desired location. Attach wires then fasten cover to mounting plate with set screw.

Optional Enhanced Weather Protection (EWP) Available:

EWP products are designed to meet IP66 standards and may feature foam rubber gaskets, sealed connections, gel-filled butt connectors, as well as potted circuit boards with internally sealed, field-adjustable trim pots and DIP switches for easy onsite programming. For more information go to www.vikingelectronics.com/ewp

Note: For greater weather resistance, apply a bead of clear silicon caulking around the top edge and sides of the chassis.

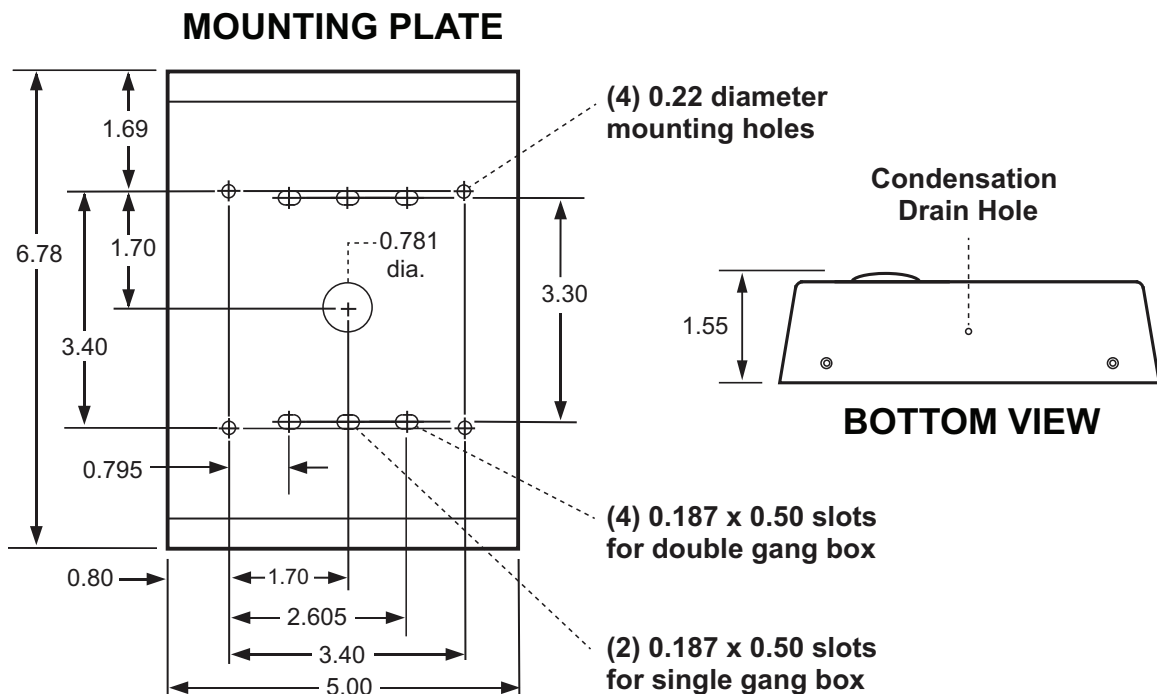
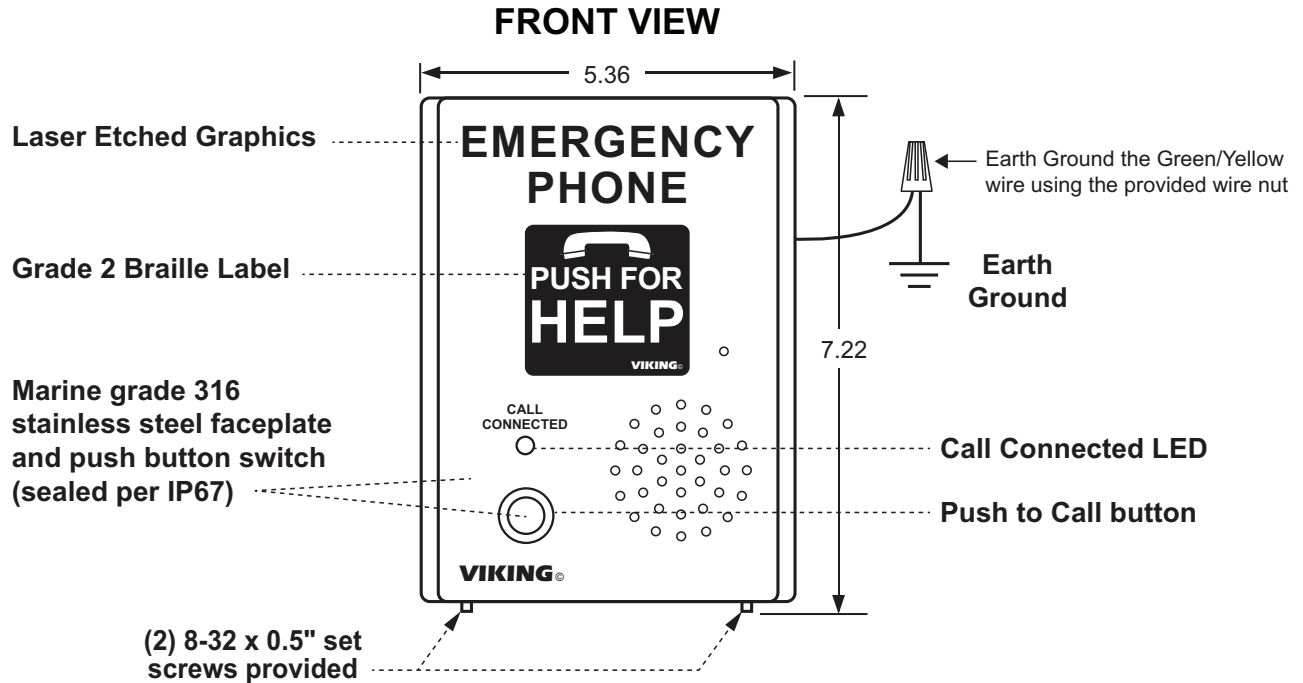

E-1600-20-IP

Dimensions: Overall: 5.0" x 5.0" x 2.25" (127mm x 127 x 57mm), Plastic Electrical Box: 4.0" x 4.0" x 2.14" (102mm x 102mm x 54mm)

Shipping Weight: 2.12 lbs (1.0 kg)

Front Panel Material: Marine grade 316 stainless steel with a #4 brushed finish

Connections: Gel-filled butt connectors

Mounting with Plastic Rough-In Box (included): Flush into walls, mounts to side of wall stud.

Mounting with Optional VE-5x5: Surface mount to walls, single gang boxes, double gang boxes, posts, or to a Viking VE-GNP Gooseneck pedestal.

Optional Enhanced Weather Protection (EWP) Available: EWP products are designed to meet IP66 standards and may feature foam rubber gaskets, sealed connections, gel-filled butt connectors, as well as potted circuit boards with internally sealed, field-adjustable trim pots and DIP switches for easy onsite programming. For more information go to www.vikingelectronics.com/ewp

Note: When mounting outside to rough or uneven surfaces (brick, stucco, etc.) apply a bead of clear silicone caulking around the top edge and sides of faceplate or VE-5x5.

Note: When European CE compliance is required, mount in optional VE-5X5 metal enclosure.

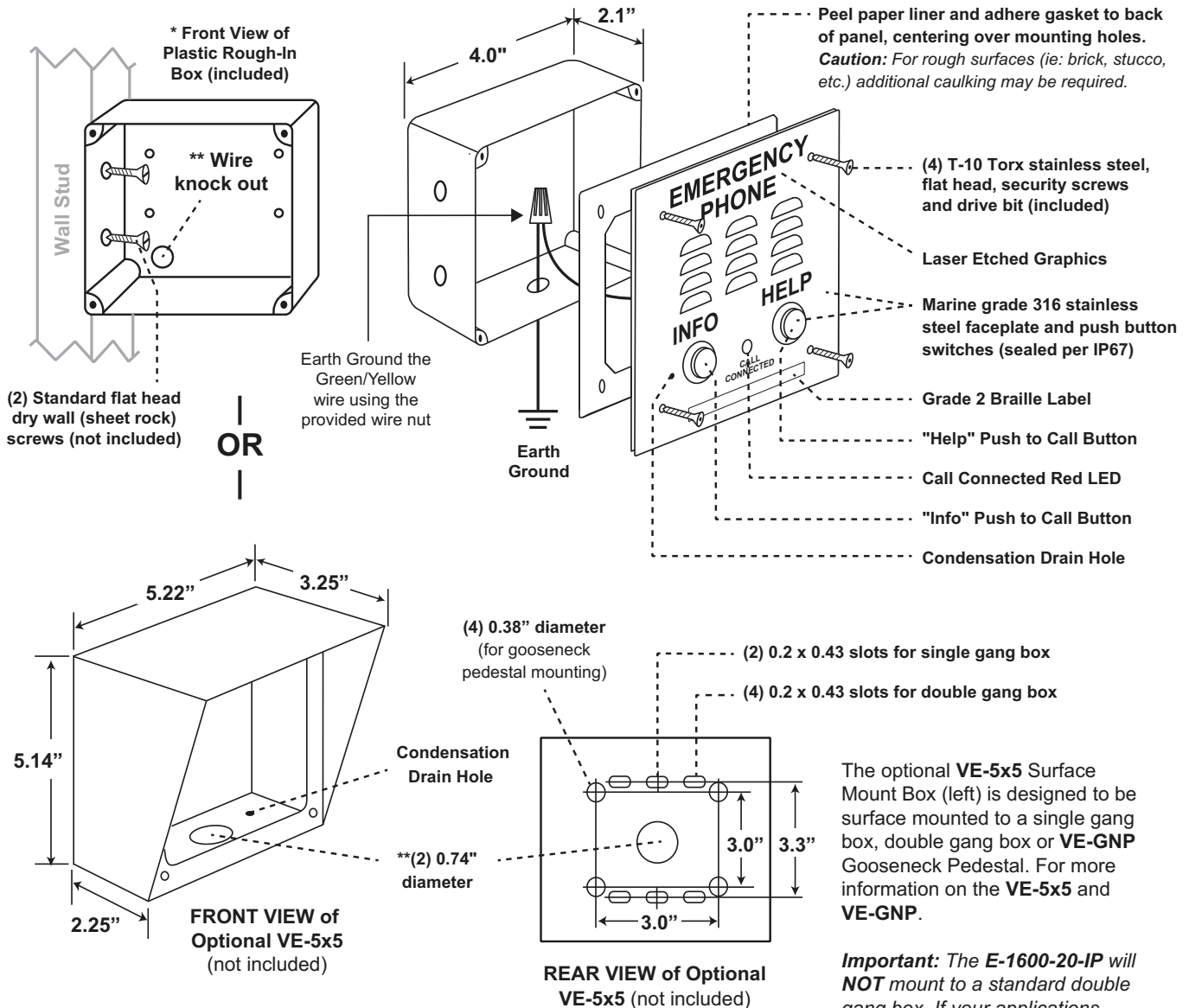

Optional VE-5x5 Surface Mount Box with black satin powder paint finish, not included. Optional VE-LIGHT kit can be used to illuminate the faceplate when used with a VE-5x5. WARNING: Do NOT use a wet location box.

Important: The E-1600-20-IP will NOT mount to a standard double gang box. If your applications requires a double gang box, see model E-1600A-22-IP.

*** Note:** The black plastic rough-in box (part # 259576) may be purchased separately (Example: Mounting boxes to studs before the walls are finished for flush installation). Go to www.vikingelectronics.com and click on "Spare Parts" to order these rough-in boxes.

**** Caution:** When warm air comes in contact with cold surfaces, such as outside walls and conduits, it causes condensation. To prevent condensation from accumulating inside the E-1600-20-IP always bring conduit into the bottom of the unit. If this is not possible, drill a 1/4" diameter hole in the bottom of the black plastic box.

E-1600-22-IP

Dimensions: 5.0" x 5.0" x 2.25" (127mm x 127 x 57mm)

Shipping Weight: 2.12 lbs (1.0 lbs)

Front Panel Material: Marine grade 316 stainless steel with a #4 brushed finish

Connections: Gel-filled butt connectors

Info Button: Dials up to 5 non-emergency phone numbers

Mounting in a Double Gang Rough-In Box (not included): Flush into walls, mounts to side of wall studs, etc.

Note: For surface mount installations, use model **E-1600-20-IP** with **VE-5x5** surface mount box.

Optional Enhanced Weather Protection (EWP) Available: EWP products are designed to meet IP66 standards and may feature foam rubber gaskets, sealed connections, gel-filled butt connectors, as well as potted circuit boards with internally sealed, field-adjustable trim pots and DIP switches for easy onsite programming. For more information go to www.vikingelectronics.com/ewp

Note: When mounting outside to rough or uneven surfaces (brick, stucco, etc.) apply a bead of clear silicone caulking around the top edge and sides of faceplate.

Note: When European CE compliance is required, mount as shown, in a metal enclosure.

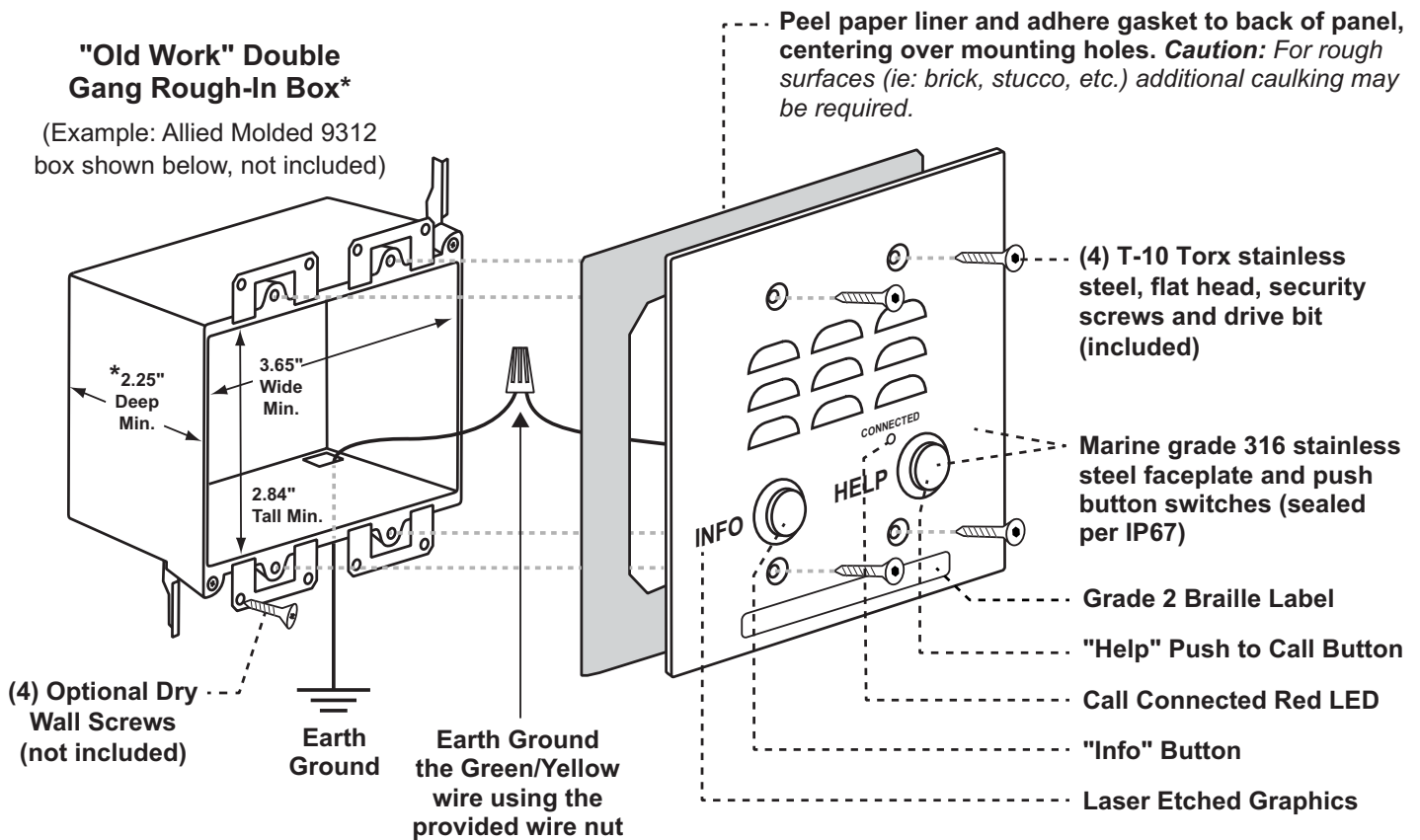

*** CAUTION:** Excessive wire length and/or using a rough-in box with inadequate depth can apply force to the circuit board causing physical damage.

Important: When warm air comes in contact with cold surfaces, such as outside walls and conduits, it causes condensation. To prevent condensation from accumulating inside the **E-1600-22-IP** always bring conduit into the bottom of the unit. If this is not possible, drill a 1/4" diameter hole in the bottom of the double gang box.

E-1600-32-IP

Dimensions: 5.0" x 5.0" x 2.25" (127mm x 127 x 57mm)

Shipping Weight: 2.12 lbs (1.0 kg)

Front Panel Material: Marine grade 316 stainless steel with a #4 brushed finish

Connections: Gel-filled butt connectors

Mounting in a Double Gang Rough-In Box (not included):
Flush into walls, mounts to side of wall studs, etc.

Note: For surface mount installations, use Model **E-1600-30-IP** with **VE-5x5** surface mount box.

Optional Enhanced Weather Protection (EWP) Available:
EWP products are designed to meet IP66 standards and may feature foam rubber gaskets, sealed connections, gel-filled butt connectors, as well as potted circuit boards with internally sealed, field-adjustable trim pots and DIP switches for easy onsite programming. For more information go to www.vikingelectronics.com/ewp

Note: When mounting outside to rough or uneven surfaces (brick, stucco, etc.) apply a bead of clear silicone caulking around the top edge and sides of faceplate.

Note: When European CE compliance is required, mount as shown, in a metal enclosure.

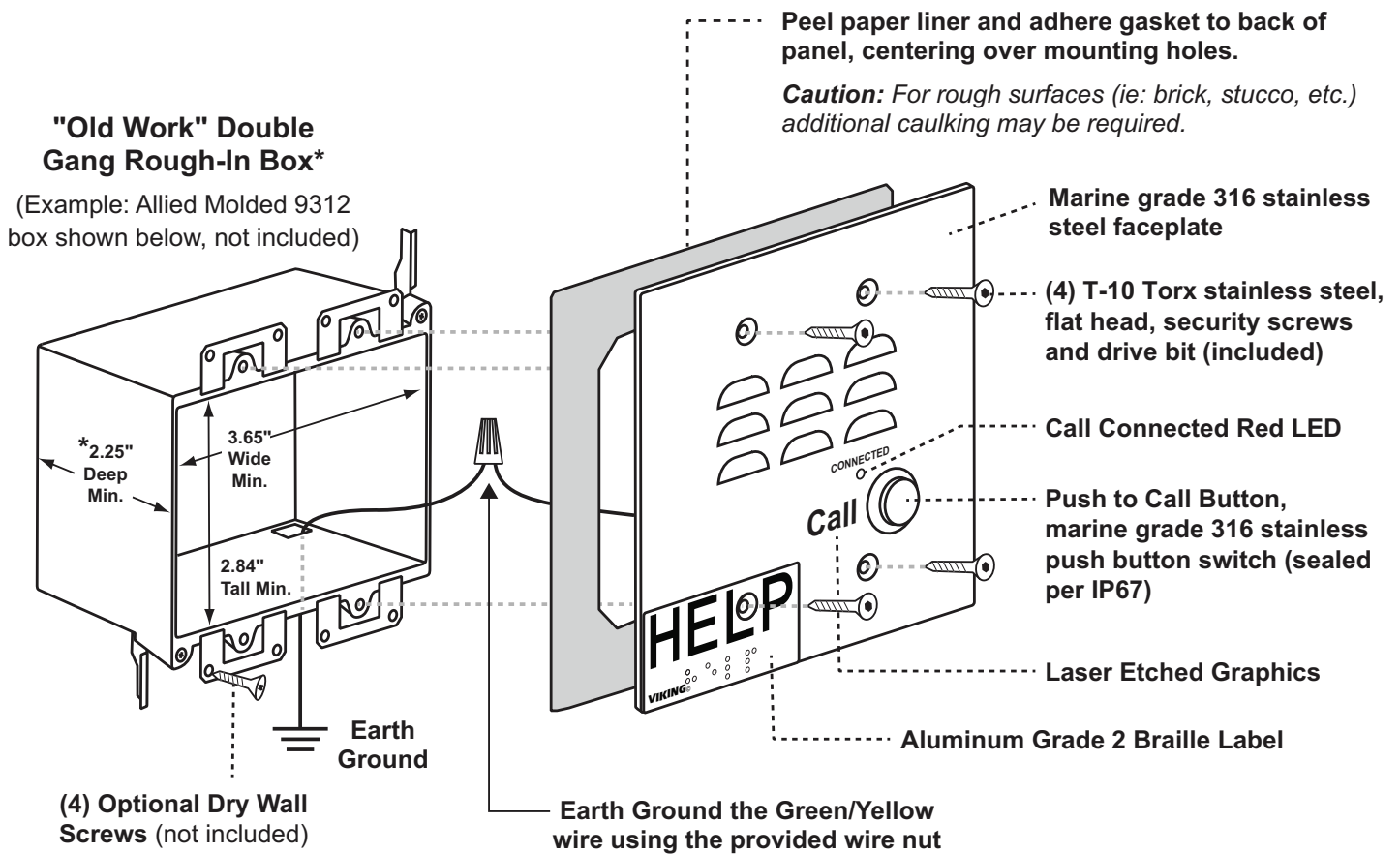

* **CAUTION:** Excessive wire length and/or using a rough-in box with inadequate depth can apply force to the circuit board causing physical damage.

Important: When warm air comes in contact with cold surfaces, such as outside walls and conduits, it causes condensation. To prevent condensation from accumulating inside the **E-1600-32-IP** always bring conduit into the bottom of the unit. If this is not possible, drill a 1/4" diameter hole in the bottom of the double gang box.

E-1600-30-IP

Dimensions: Overall - 5.0" x 5.0" x 2.25" (127mm x 127 x 57mm), Plastic Electrical Box - 4.0" x 4.0" x 2.14" (102mm x 102mm x 54mm)

Shipping Weight: 2.12 lbs (1.0 kg)

Front Panel Material: Marine grade 316 stainless steel with a #4 brushed finish

Connections: Gel-filled butt connectors

Mounting with Plastic Rough-In Box (included): Flush into walls, mounts to side of wall stud

Mounting with Optional VE-5x5: Surface mount to walls, single gang boxes, double gang boxes, posts, or to a Viking Gooseneck pedestal.

Optional Enhanced Weather Protection (EWP) Available: EWP products are designed to meet IP66 standards and may feature foam rubber gaskets, sealed connections, gel-filled butt connectors, as well as potted circuit boards with internally sealed, field-adjustable trim pots and DIP switches for easy onsite programming. For more information go to www.vikingelectronics.com/ewp

**** Important:** Optional Braille "Push for Help" label should be adhered to the faceplate in ADA applications. Clean surface with isopropyl alcohol, peel off backing and press firmly to the front panel in location as shown.

Note: When European CE compliance is required, mount in optional VE-5X5 metal enclosure.

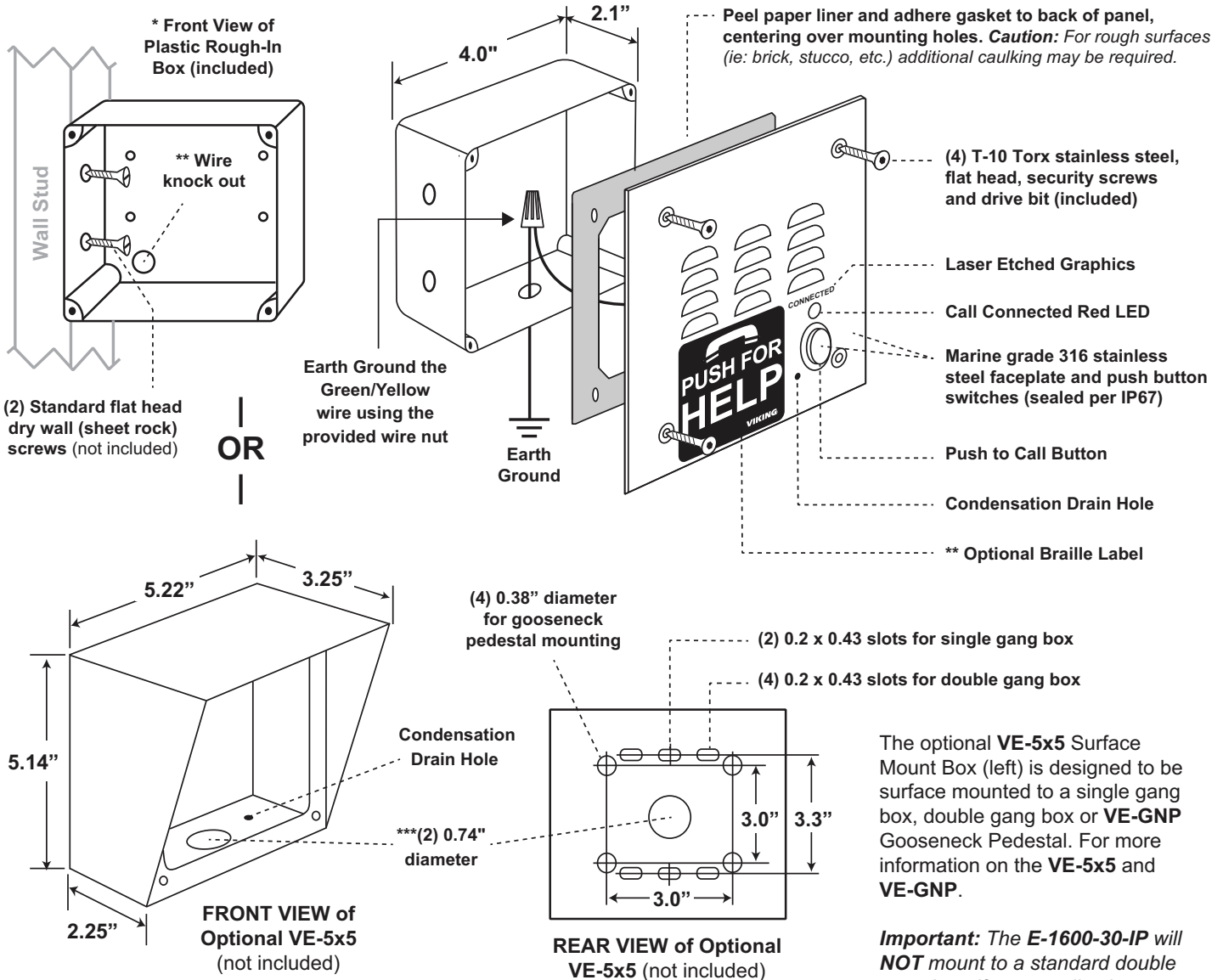

Optional VE-5x5 Surface Mount Box with black satin powder paint finish, not included. Optional VE-LIGHT kit can be used to illuminate the faceplate when used with a VE-5x5. WARNING: Do NOT use a wet location box.

Important: The E-1600-30-IP will NOT mount to a standard double gang box. If your applications requires a double gang box, see model E-1600A-32-IP.

*** Note:** The black plastic rough-in box (part # 259576) may be purchased separately (Example: Mounting boxes to studs before the walls are finished for flush installation). Go to www.vikingelectronics.com and click on "Spare Parts" to order these rough-in boxes.

***** Caution:** When warm air comes in contact with cold surfaces, such as outside walls and conduits, it causes condensation. To prevent condensation from accumulating inside the E-1600-30-IP always bring conduit into the bottom of the unit. If this is not possible, drill a 1/4" diameter hole in the bottom of the black plastic box.

E-1600-50-IP / E-1600-52-IP

This is a **E-1600-IP** Emergency Phone "parts kits" without a chassis. It is specifically designed to be used behind custom elevator panels or with custom elevator phones. Just like all Viking ADA Compliant Emergency Phones, these kits provide quick and reliable handsfree communication in the event of an emergency.

Shipping Weight: 1.0 lb (0.45 kg)

Connections: Gel-filled butt connectors

Optional Enhanced Weather Protection (EWP) Available: EWP products are designed to meet IP66 standards and may feature foam rubber gaskets, sealed connections, gel-filled butt connectors, as well as potted circuit boards with internally sealed, field-adjustable trim pots and DIP switches for easy onsite programming. For more information go to www.vikingelectronics.com/ewp

Note: When European CE compliance is required, mount in a metal enclosure.

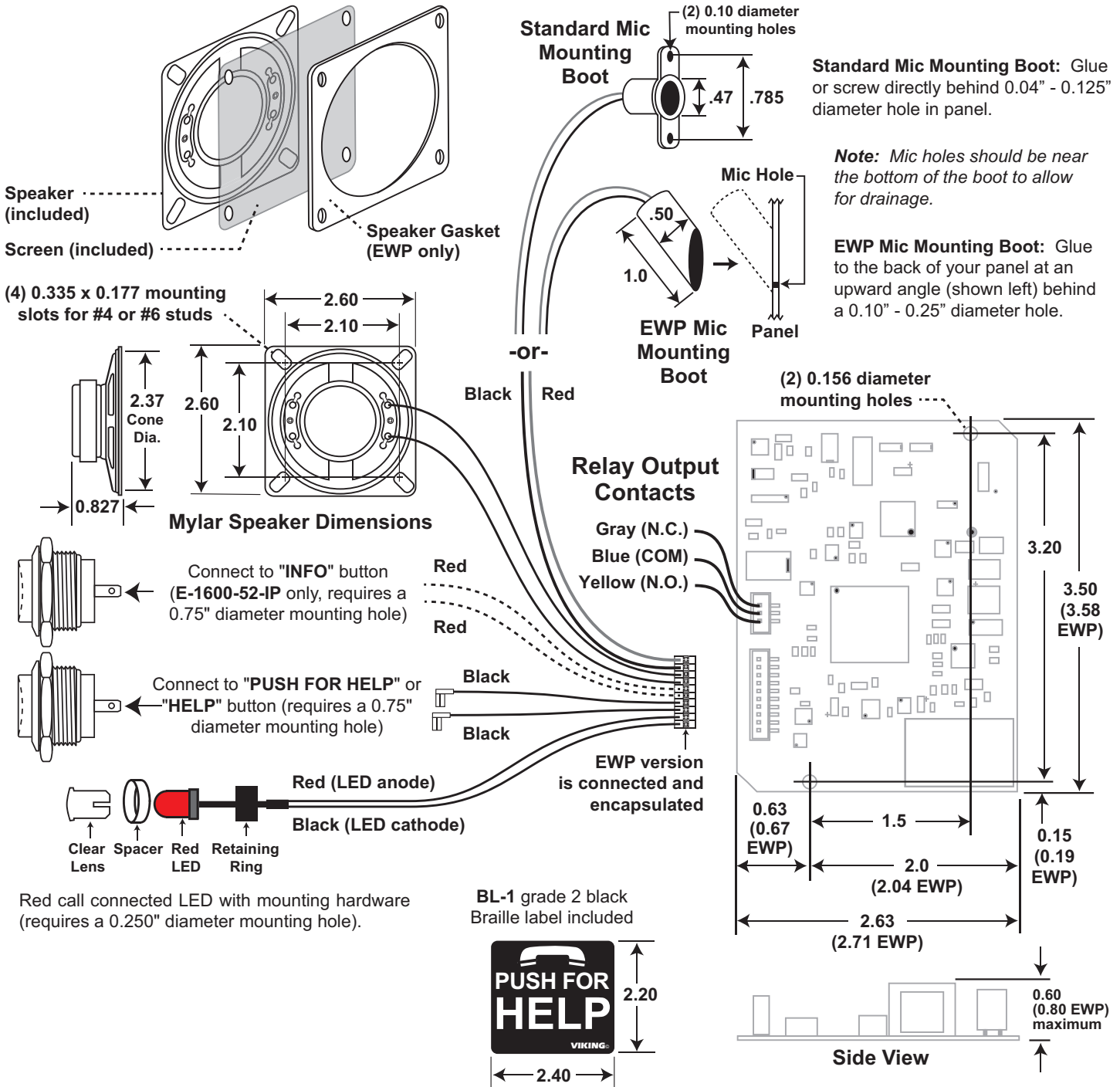

E-1600-53-IP

This is a **E-1600-IP** board (PCB) only kit. This kit can be used to convert 2008 or newer Viking **1600A Series** Analog Emergency Phones to a VoIP version. A special connector and microphone assembly is required to convert 2007 and older Viking 1600A Series Emergency Phones. Contact Viking Technical Support if attempting to install this kit in these older phones. This kit can also be used to replace a damaged "IP" board in the field.

Shipping Weight: 1.0 lb (0.45 kg)

Connections: (1) RJ45 10/100 Base-T, (3) optional gel-filled butt connectors

Note: When European CE compliance is required, mount in a metal enclosure.

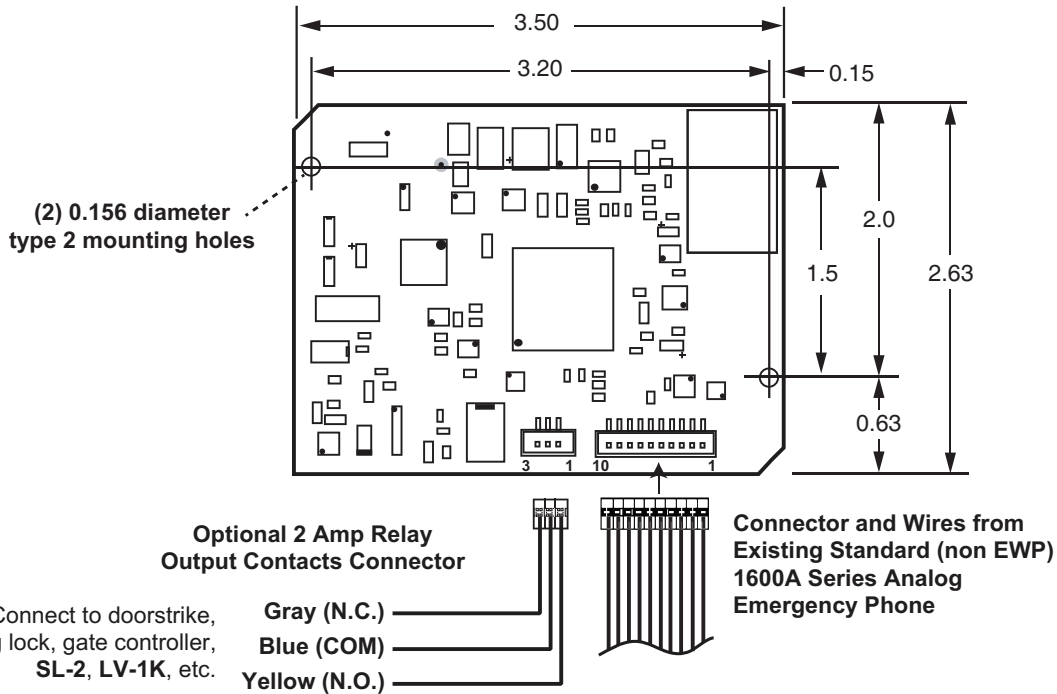

E-1600-53-IP-EWP

This is a **E-1600-IP-EWP** board (PCB) only kit. This kit can be used to convert any Viking 1600A-EWP Series Analog Emergency Phone to a VoIP version. The kit can also be used to replace a damaged "IP" board in the field.

Shipping Weight: 1.0 lb (0.45 kg)

Connections: (1) RJ45 10/100 Base-T, (13) gel-filled butt connectors

Note: When European CE compliance is required, mount in a metal enclosure.

Enhanced Weather Protection (EWP) Included: EWP products are designed to meet IP66 standards and may feature foam rubber gaskets, sealed connections, gel-filled butt connectors, as well as potted circuit boards with internally sealed, field-adjustable trim pots and DIP switches for easy onsite programming. For more information go to www.vikingelectronics.com/ewp

Replacing Analog 1600A Series EWP Potted Circuit Boards:

Step 1.	Cut wires from J1 (10 pin connector) and J2 (3 pin connector).
Step 2.	Remove the two #6 phillips screws fastening the circuit board.
Step 3.	Cut off any stripped wire ends from the replacement cable.
Step 4.	Using the supplied gel-filled butt connectors, connect corresponding wires from replacement cable to the previously cut wires from the LED, Help/Call switch, optional Info switch, Speaker and Microphone. See FIGURE 1 for wire color and polarity.

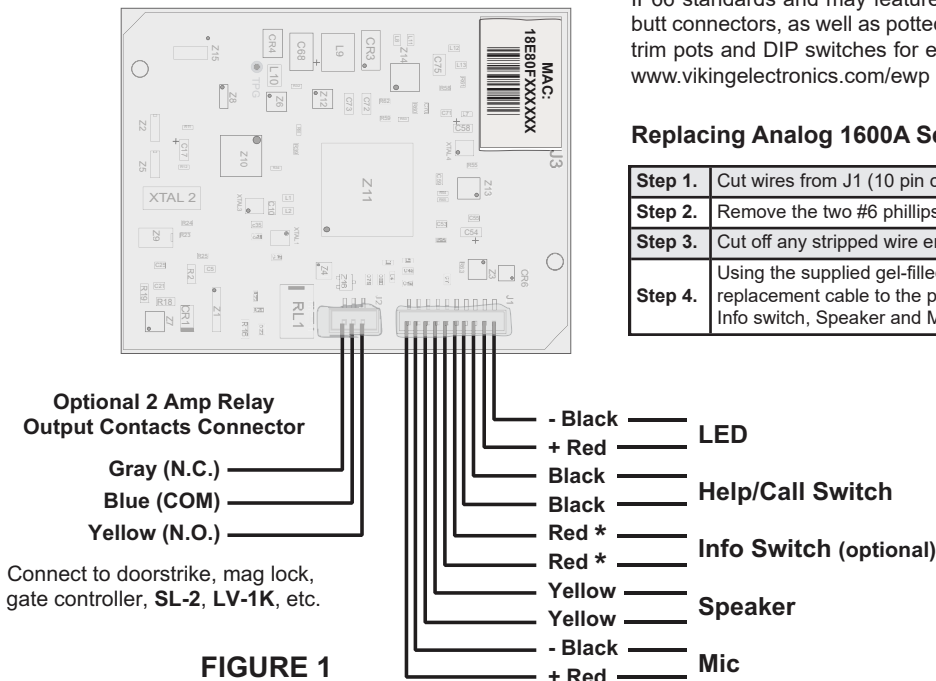

FIGURE 1

*** Note:** These two red wires are only used on units with an Info button. When installing on a single button unit, cut off these two red wires and discard.

E-1600-54-IP

The **E-1600-54-IP** is a universal VoIP emergency phone retrofit kit for replacing an existing "behind the elevator panel" emergency phone.

Butt connectors are provided allowing you to simply cut the existing wires and attach to the appropriate wire colors from the **E-1600-54-IP** box. Strong 3M VHB double-sided tape is used to securely mount the mic, speaker, and phone board mounting box.

See installation instructions and wiring diagram below.

Shipping Weight: 1.0 lbs (0.45 kg)
Connections: (7) gel-filled butt connectors
Material: Black UL 94 VO ABS plastic

The elevator panel should provide:

- Audio holes for speaker and microphone
- Momentary SPST push button switch
- LED or switch with integrated LED

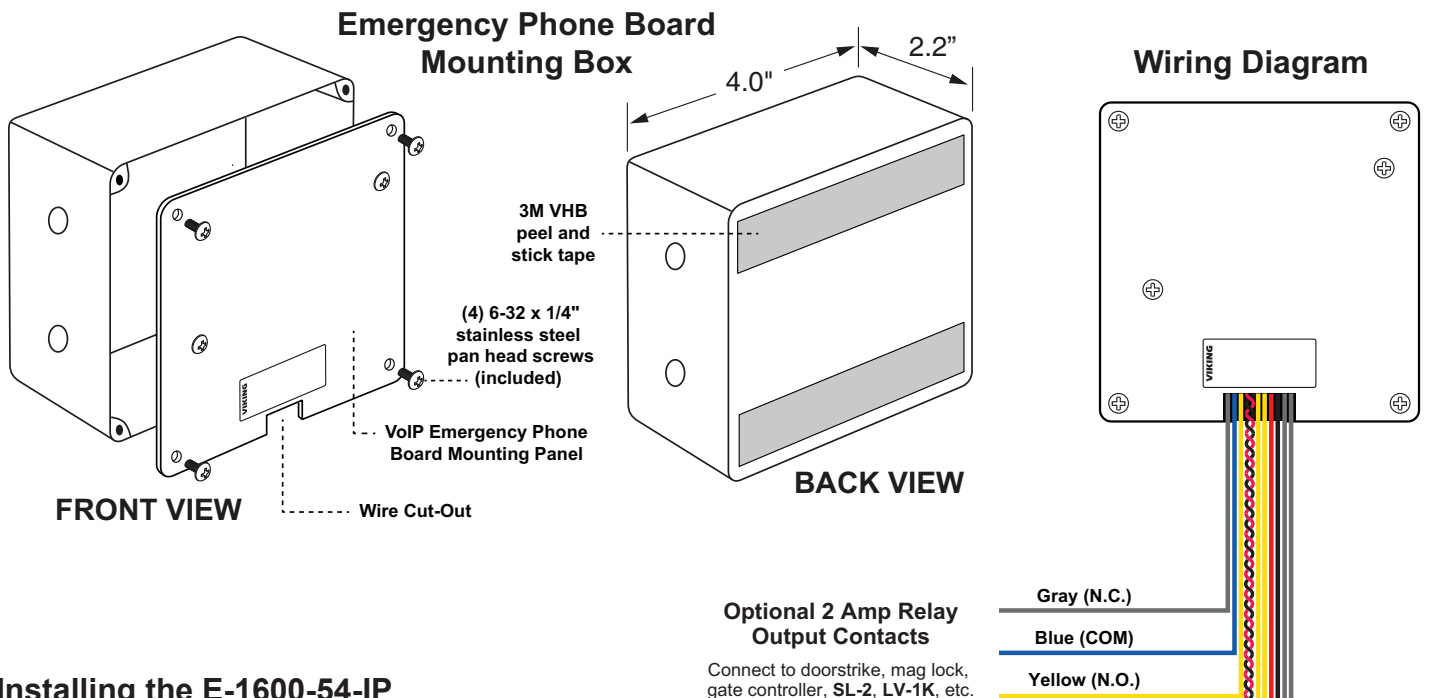

Installing the E-1600-54-IP

Step 1	Remove the existing mic, speaker, and phone board.
Step 2	Clean the mounting surfaces with the included alcohol pad.
Step 3	Adhere the mounting box using the peel and stick tape.
Step 4	Adhere the peel and stick mic and peel and stick speaker over the audio holes.
Step 5	Connect CAT5 or greater twisted pair wire with RJ45 plug to the RJ45 jack and to your LAN with PoE.
Step 6	Connect the red (+) and black (-) wires to the existing LED using the included gel-filled butt connectors.
Step 7	Connect the gray wires to the existing push button switch using the included gel-filled butt connectors.

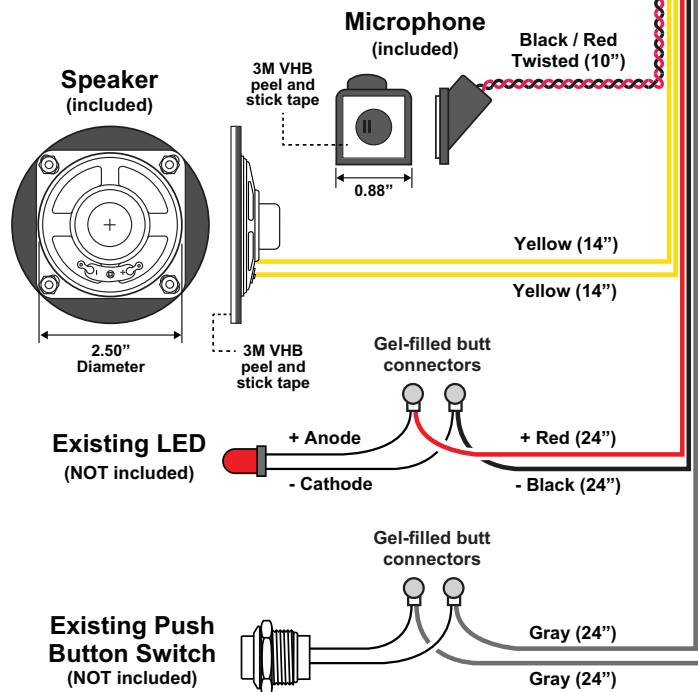

E-1600-55-IP

The **E-1600-55-IP** is a universal emergency phone kit for installing behind elevator panels, or an installation requiring a custom panel. The finished panel should provide: (4) studs (#6 diameter minimum) for mounting plate, audio holes for speaker and microphone, a momentary SPST push button switch and a 0.25" diameter mounting hole for the LED. Alternatively, the LED can be cut off and the wires connected to a integral switch with LED (often found in elevators).

Optional Enhanced Weather Protection (EWP) Available: EWP products are designed to meet IP66 standards and may feature foam rubber gaskets, sealed connections, gel-filled butt connectors, as well as potted circuit boards with internally sealed, field-adjustable trim pots and DIP switches for easy onsite programming. For more information go to www.vikingelectronics.com/ewp

Shipping Weight: 1.6 lbs (0.73 kg)

Connections: (1) RJ45 10/100 Base-T, (5) gel-filled butt connectors

Material: Zinc plated steel

Note: When European CE compliance is required, mount in a metal enclosure.

Plastic Dust Cover (included)

Install prior to fastening the faceplate to finished panel.

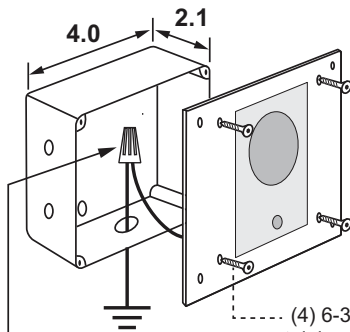

Earth Ground

Earth Ground the Green/Yellow wire using the provided wire nut

(4) 6-32 x 3/4" stainless steel flat head, 5/64" hexdrive, screws (included) for fastening dust cover

2 Amp Relay Output Contacts

Gray (N.C.)
Blue (COM.)
Yellow (N.O.)

Connect to momentary push button switch with contact rating of 50VDC/100mA min

Black

Black

Additional wire length may be added if required

Red "Call Connected" LED with included mounting hardware (requires a 0.25" diameter hole)



Clear Lens



Spacer

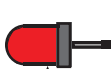

Red 5mm Round LED



Retaining Ring

Red (LED anode)

Black (LED cathode)

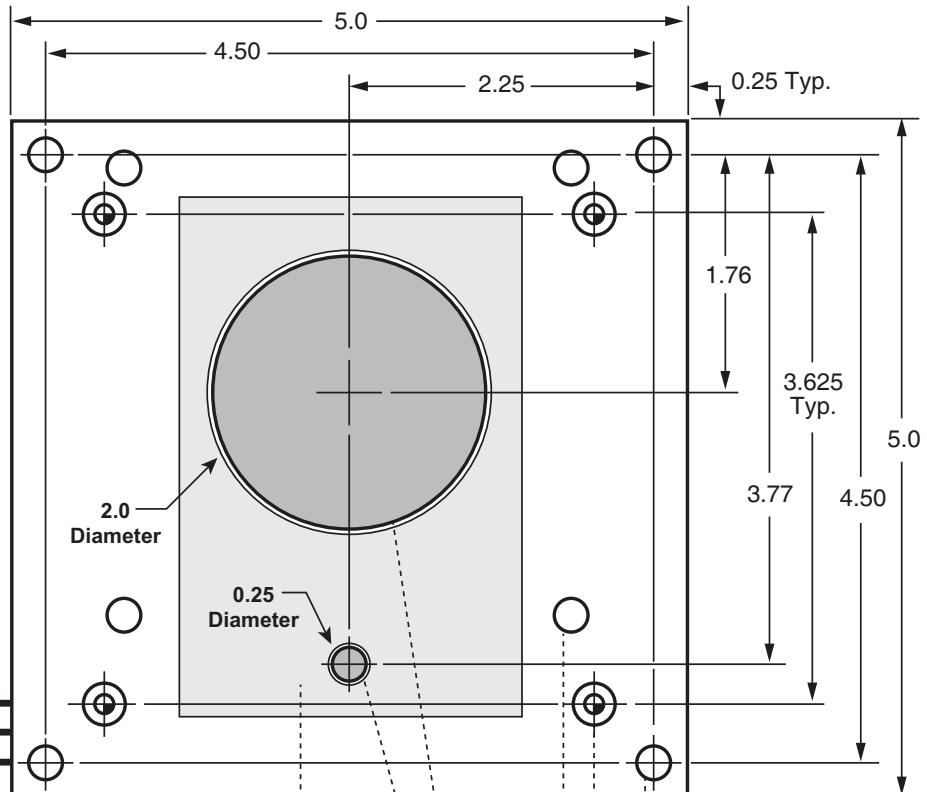

(4) 0.25 diameter clearance holes for mounting the unit to the back side of a finished panel.

(4) Countersunk holes for mounting the dust cover

(4) 0.25 diameter holes (not used)

304 stainless steel speaker and microphone protection screens

1/16" thick foam gasket (included) for acoustically sealing mic and speaker to back of finished panel. Remove backing and adhere gasket to front panel of the E-1600-55-IP, centering over speaker and microphone holes (as shown).

Note: If you do not want to use the LED, tuck it inside the unit. **Do NOT cut it off.**

E-1600-912-IP

Dimensions: 11.225" x 7.08" x 2.0" (299mm x 216mm x 51mm)
Shipping Weight: 2.3 lbs (1.04 kg)
Mounting: Mounts to Viking model **VE-9X12(R/Y/B)-0P**
Material: Marine grade 316 stainless steel with a #4 brushed finish
Connections: (1) RJ45 10/100 Base-T, color-coded wires with gel-filled butt connectors

Optional Enhanced Weather Protection (EWP): EWP products are designed to meet IP66 standards and may feature foam rubber gaskets, sealed connections, gel-filled butt connectors, as well as potted circuit boards with internally sealed, field-adjustable trim pots and DIP switches for easy onsite programming. For more information go to www.vikingelectronics.com/ewp

Note: When European CE compliance is required, mount onto a metal enclosure.

A. Installing the E-1600-912-IP into the VE-9x12(R/Y/B)-0P (not included)

Step 1	Mount the VE-9x12(R/Y/B)-0P to the wall or desired surface.
Step 2	Run the conduit and wiring as appropriate.
Step 3	Attach standoffs to VE-9X12 using (4) included 5/8 inch 8-32 M/F standoffs then attach E-1600-912-IP to VE-9X12 using (4) included 8-32 x 3/8 pan head hex drive screws.

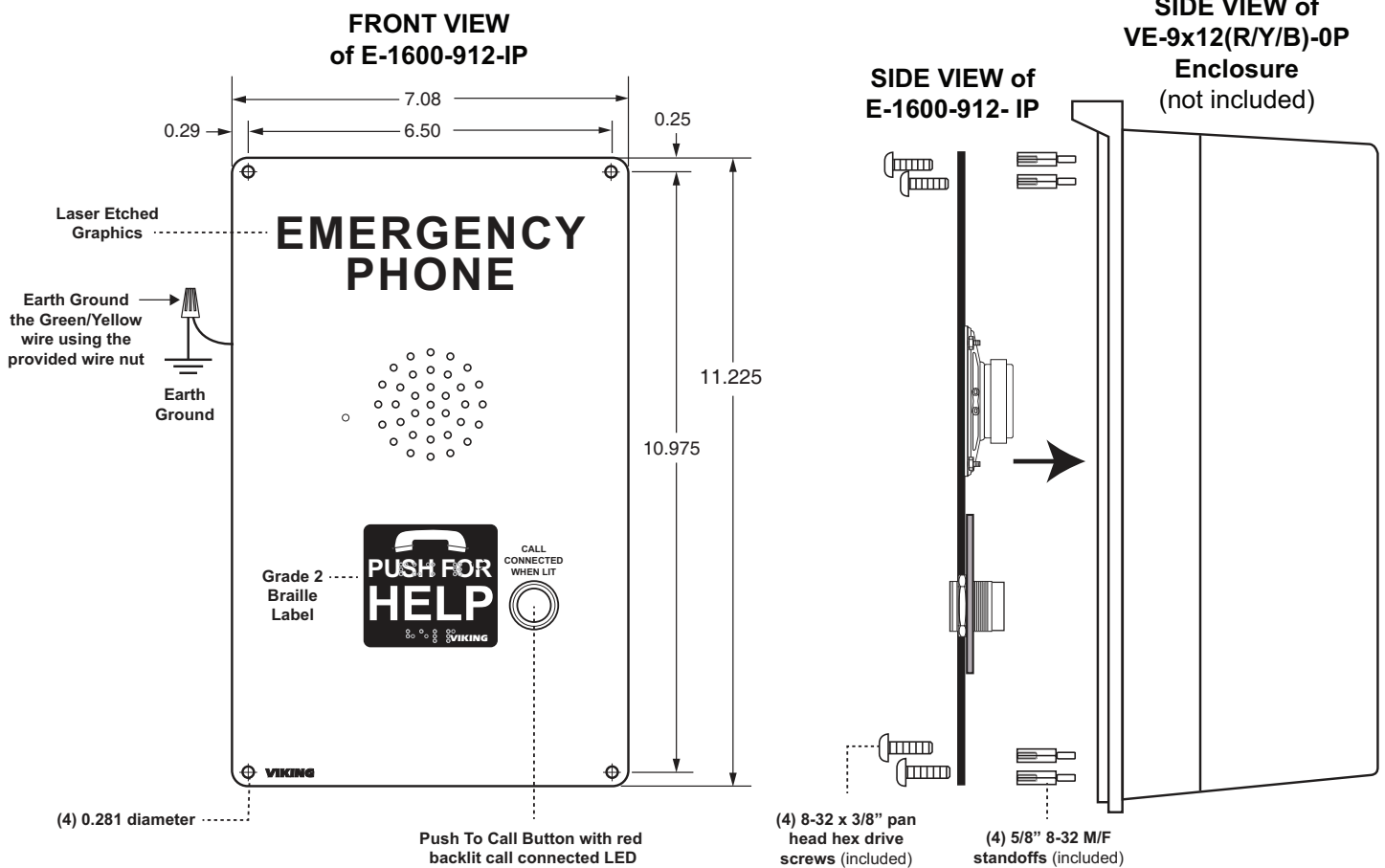

B. Optional VE-SPG Door Return Hinge Spring

An optional **VE-SPG** door return hinge spring is available to assure the door is closed after use. Please contact your distributor for pricing and availability.

C. Adhering the "Telephone" Label on the VE-9x12(R/Y/B)-0P

Step 1	Clean the recessed area on the door cover with isopropol alcohol.
Step 2	Make sure the outside edges of the "Telephone" label are not warped upward (re-form if necessary). Remove backing paper, then firmly press label in recessed area on the front cover.

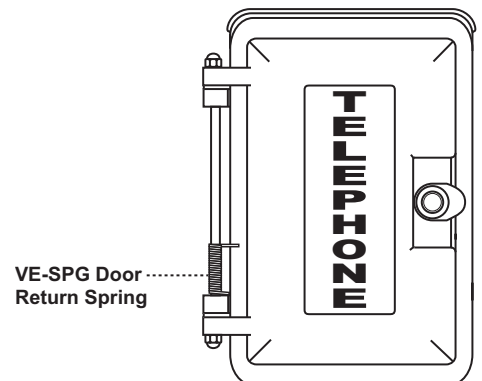

Note: Optional 261529 Red "Emergency Label", <https://store.vikingelectronics.com/>

E-1600-GT-IP-EWP

Dimensions: 10.0" x12.0" x 2.0" (254mm x 305mm x 51mm)

Shipping Weight: 6.4 lbs (2.9 kg)

Mounting: Flush mount to GAI-TRONICS towers, wall mounts, boxes and pedestals

Material: Marine grade 316 stainless steel with a #4 brushed finish

Connections: (1) RJ45 10/100 Base-T, color-coded wires with gel-filled butt connectors

Enhanced Weather Protection (EWP): EWP products are designed to meet IP66 standards and may feature foam rubber gaskets, sealed connections, gel-filled butt connectors, as well as potted circuit boards with internally sealed, field-adjustable trim pots and DIP switches for easy onsite programming. For more information go to www.vikingelectronics.com/ewp

Note: When European CE compliance is required, mount onto a metal enclosure.

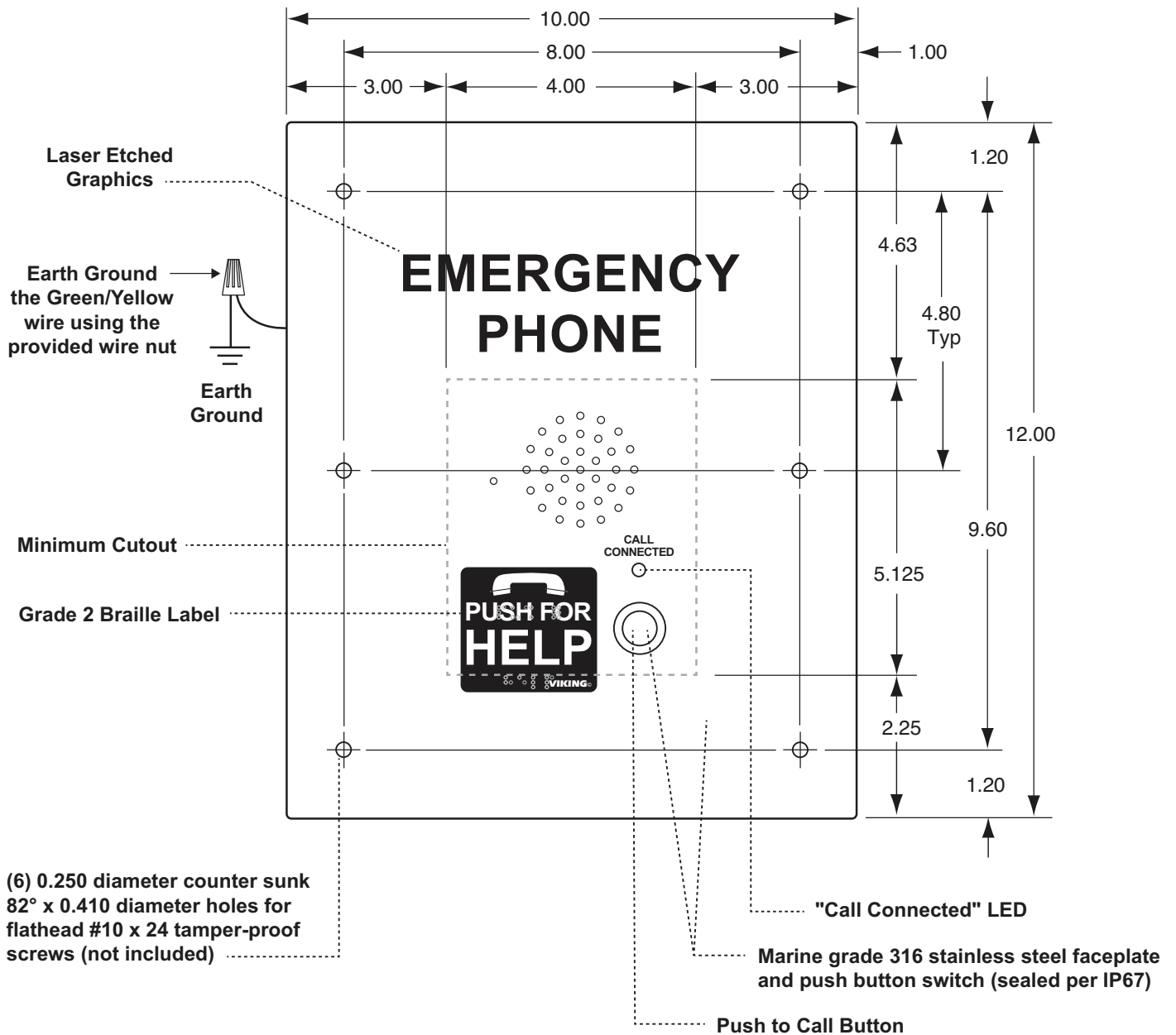

E-1600-RT-IPEWP

Dimensions: 8.281" x 11.938" x 2.0" (210 mm x 303mm x 51mm)

Shipping Weight: 3.1 lbs (1.41 kg)

Mounting: Flush mount to RAMTEL PLC columns, towers, wall mounts, 926 and 906 boxes and pedestals

Material: Marine grade 316 stainless steel with a #4 brushed finish

Connections: (1) RJ45 10/100 Base-T, color-coded wires with gel-filled butt connectors

Enhanced Weather Protection (EWP): EWP products are designed to meet IP66 standards and may feature foam rubber gaskets, sealed connections, gel-filled butt connectors, as well as potted circuit boards with internally sealed, field-adjustable trim pots and DIP switches for easy onsite programming. For more information go to www.vikingelectronics.com/ewp

Note: When European CE compliance is required, mount onto a metal enclosure.

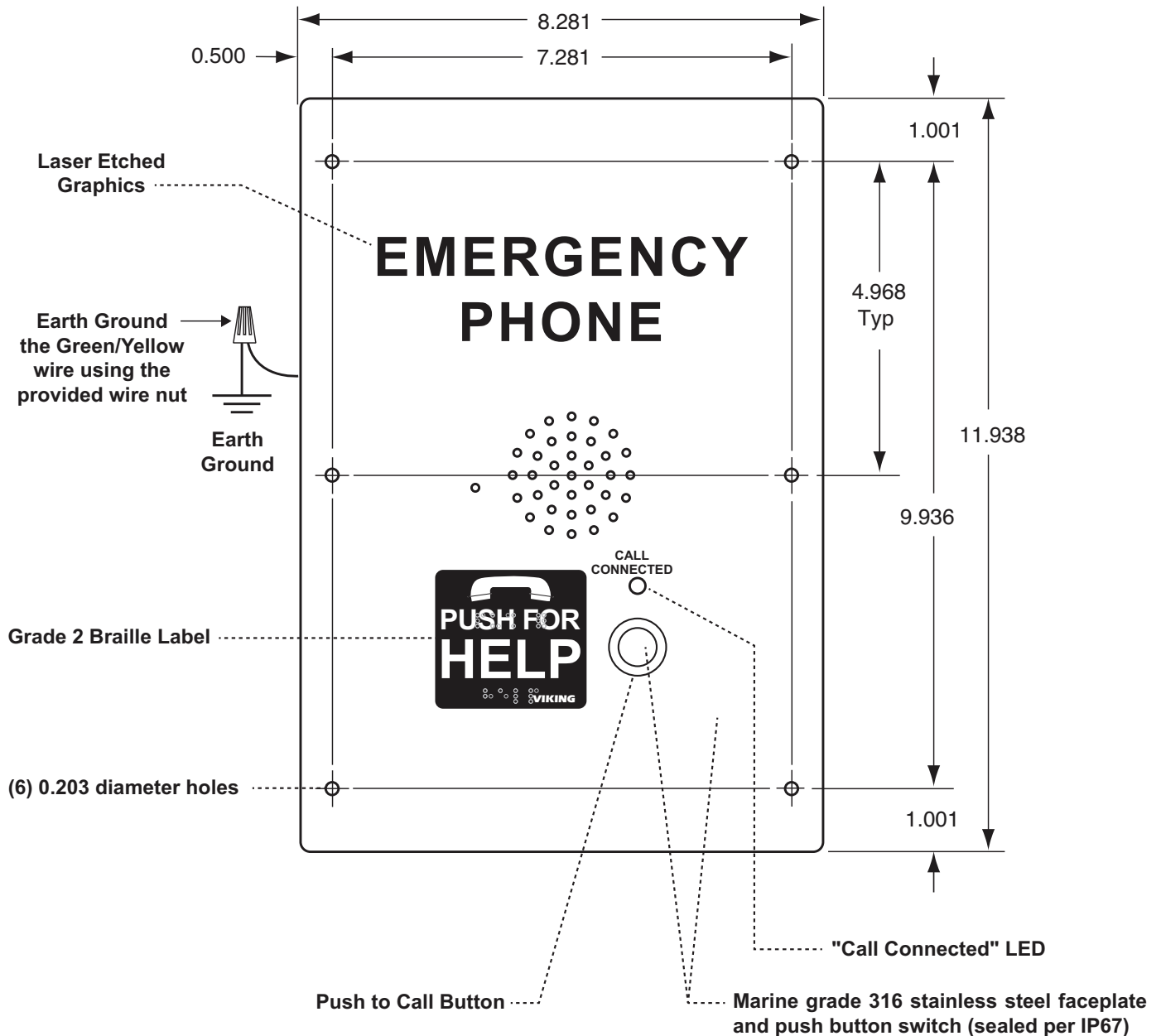

E-1600-RTMPEWP

Dimensions: 6.50" x 8.50" x 2.0" (165 mm x 216mm x 51mm)

Shipping Weight: 2.0 lbs (0.91 kg)

Mounting: Flush mount to RAMTEL MINI columns, towers, wall mounts, 924 and 904 boxes and pedestals

Material: Marine grade 316 stainless steel with a #4 brushed finish

Connections: (1) RJ45 10/100 Base-T, color-coded wires with gel-filled butt connectors

Enhanced Weather Protection (EWP): EWP products are designed to meet IP66 standards and may feature foam rubber gaskets, sealed connections, gel-filled butt connectors, as well as potted circuit boards with internally sealed, field-adjustable trim pots and DIP switches for easy onsite programming. For more information go to www.vikingelectronics.com/ewp

Note: When European CE compliance is required, mount onto a metal enclosure.

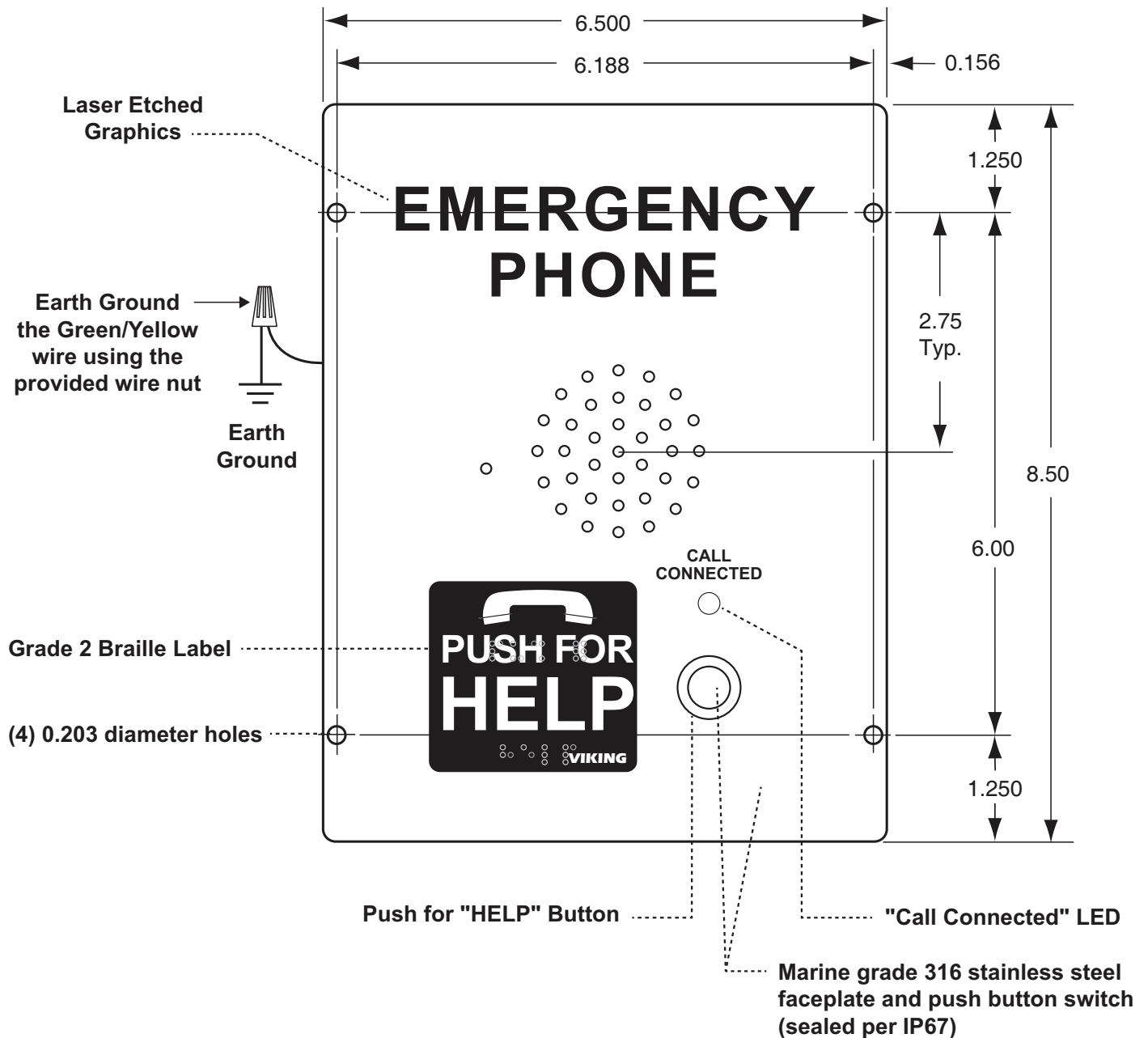

E-1600-TP-IP-EWP / E-1600-TP2-IP-EWP

Dimensions: 9.5" x 11.75" x 2.0" (241mm x 299mm x 51mm)

Shipping Weight: 6.4 lbs (2.9 kg)

Mounting: Flush mount to Talk-A-Phone ETP towers, wall mounts, boxes and pedestals

Material: Marine grade 316 stainless steel with a #4 brushed finish

Connections: (1) RJ45 10/100 Base-T, color-coded wires with gel-filled butt connectors

Enhanced Weather Protection (EWP): EWP products are designed to meet IP66 standards and may feature foam rubber gaskets, sealed connections, gel-filled butt connectors, as well as potted circuit boards with internally sealed, field-adjustable trim pots and DIP switches for easy onsite programming. For more information go to www.vikingelectronics.com/ewp

Note: When European CE compliance is required, mount onto a metal enclosure.

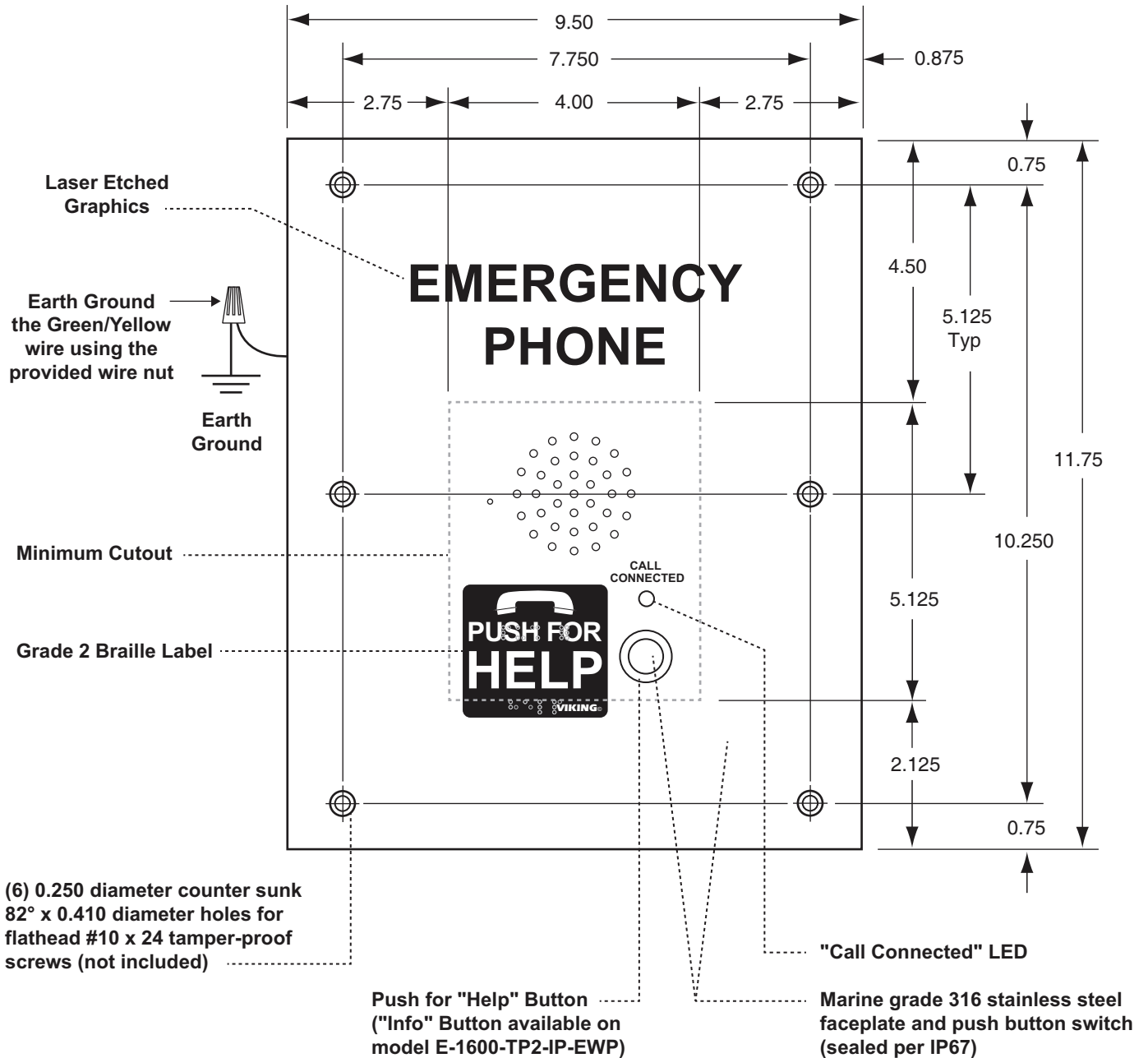

Typical Installation on SIP Based VoIP Phone System

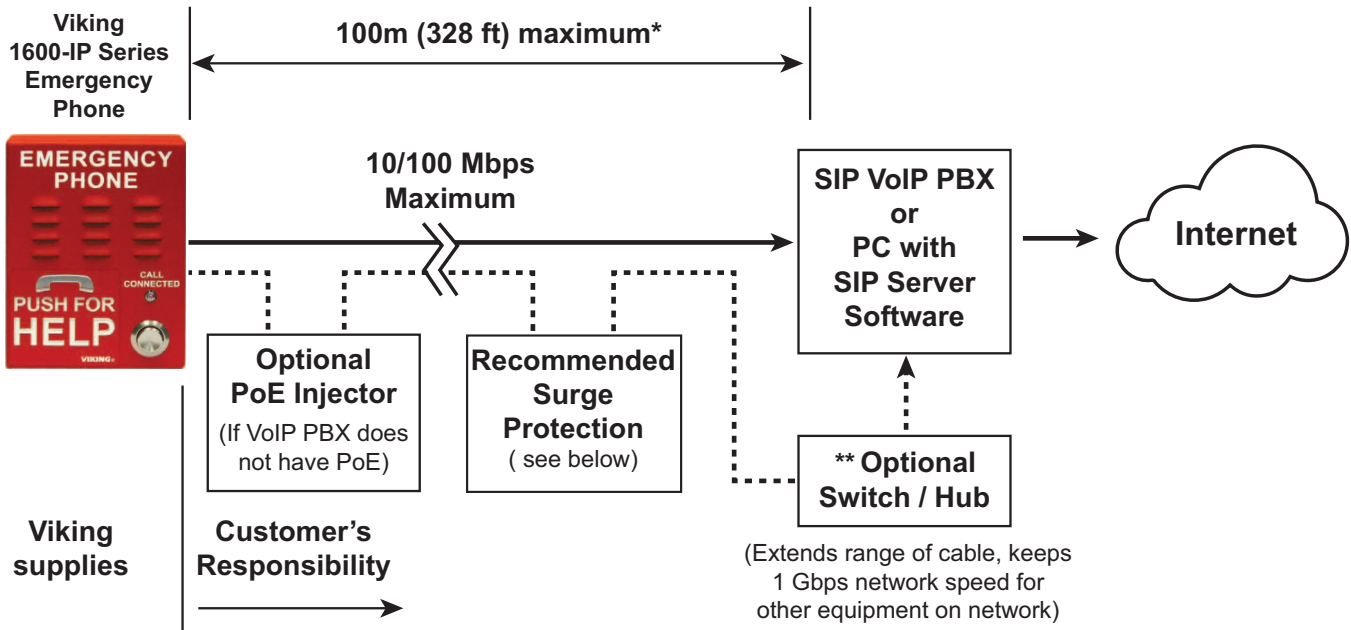

* **Note:** A PoE extender can be used for an additional 100 meters per extender. For longer runs (up to 2 km / 1.2 miles) an ethernet to fiber media converter can be used.

** Network Port Settings

- Make sure the port is not in trunk mode
- Make sure port is capable of 100Mbps full duplex
- Disable Spanning Tree Protocol (STP) or enable PortFast

PC Requirements

- IBM compatible personal computer with: Windows 10 or 11
- Adobe Acrobat Reader 8 or higher
- Available LAN with PoE (class 1, < 4 Watts)
- Ethernet cable (CAT5 minimum)
- 512 MB minimum free hard drive space for installation
- 128 MB of free physical RAM

Surge Protection

To prevent ESD and power surges from damaging hardware install a surge protector (for both the power and data pairs). The links below are examples of suitable devices:

For Indoor Applications:
Tripp Lite B110-SP-POE-1



For Outdoor Applications:
Tripp Lite B110-SP-CAT-OD2



PC Programming

Download and install the management software

1. Go to www.vikingelectronics.com and enter **E-1600-IP** in the search box
2. Click **E-1600-IP** in the search results
3. Under Software & Downloads, click **Viking Device Manager**
4. Install the management software by saving or opening the file and then clicking on **VDM-win-setup.exe**
5. Follow the prompts on your screen to complete software installation
6. To start the application, click on the icon on your desktop. The main screen will appear, allowing the user to program any **E-1600-IP** connected to that LAN.

Note: PC must be connected to the same LAN as the **E-1600-IP**.

A. Discover and Connect

Open “Viking Device Manager” on the PC and the “Network Devices - Connected Devices” window below is shown. Click “Discovered Devices” in the lower right corner.

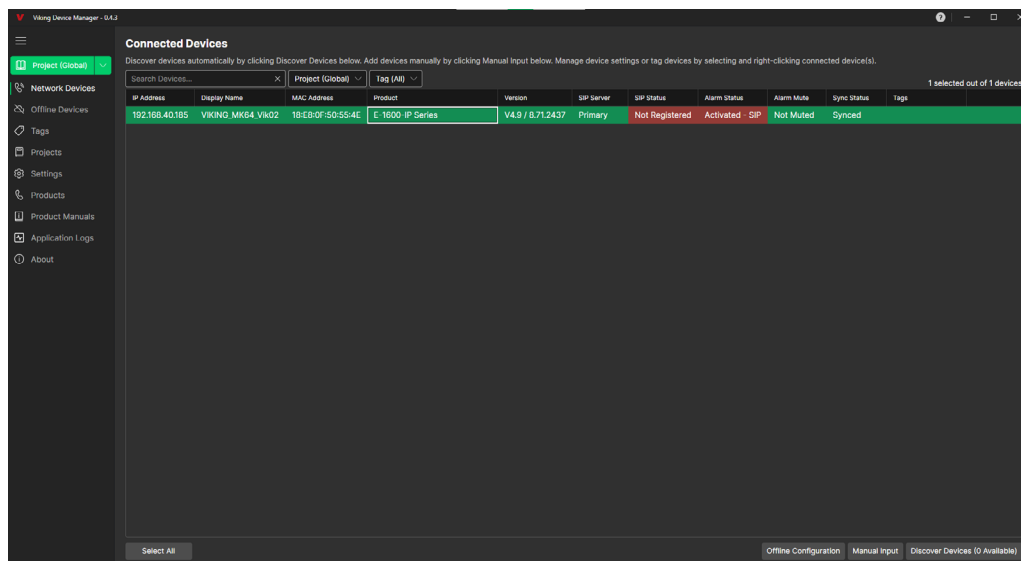

Select a unit (or multiple units) and click “connect”. If this is the first time connecting to a unit, the security window will be shown with the default Security Code (845464). If this code has been changed, enter it here to finish connecting. An option is provided to encrypt and save the credentials on the first connection.

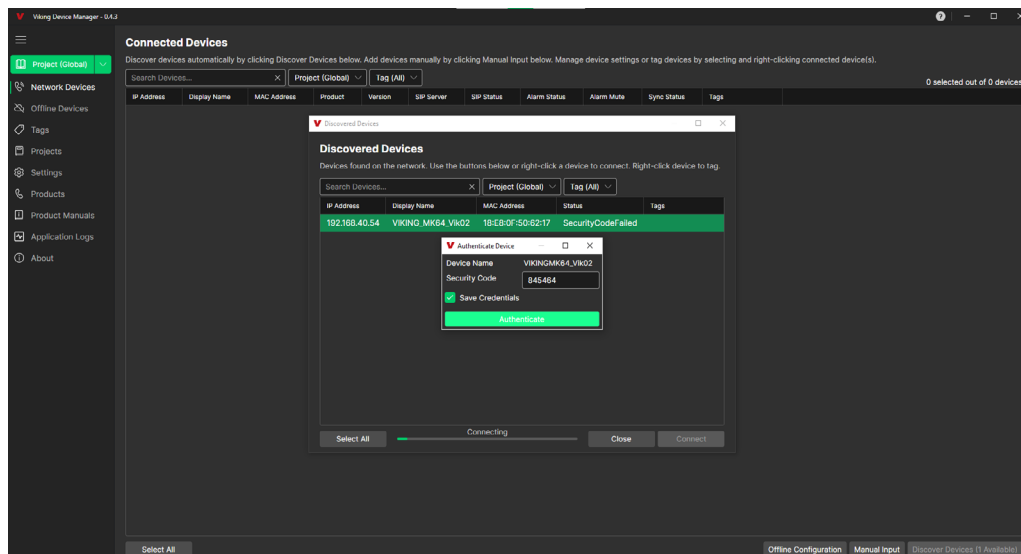

Successfully connected devices are shown in the “Network Devices - Connected Devices” window along with unit information such as Firmware revisions levels and Alarm Status.

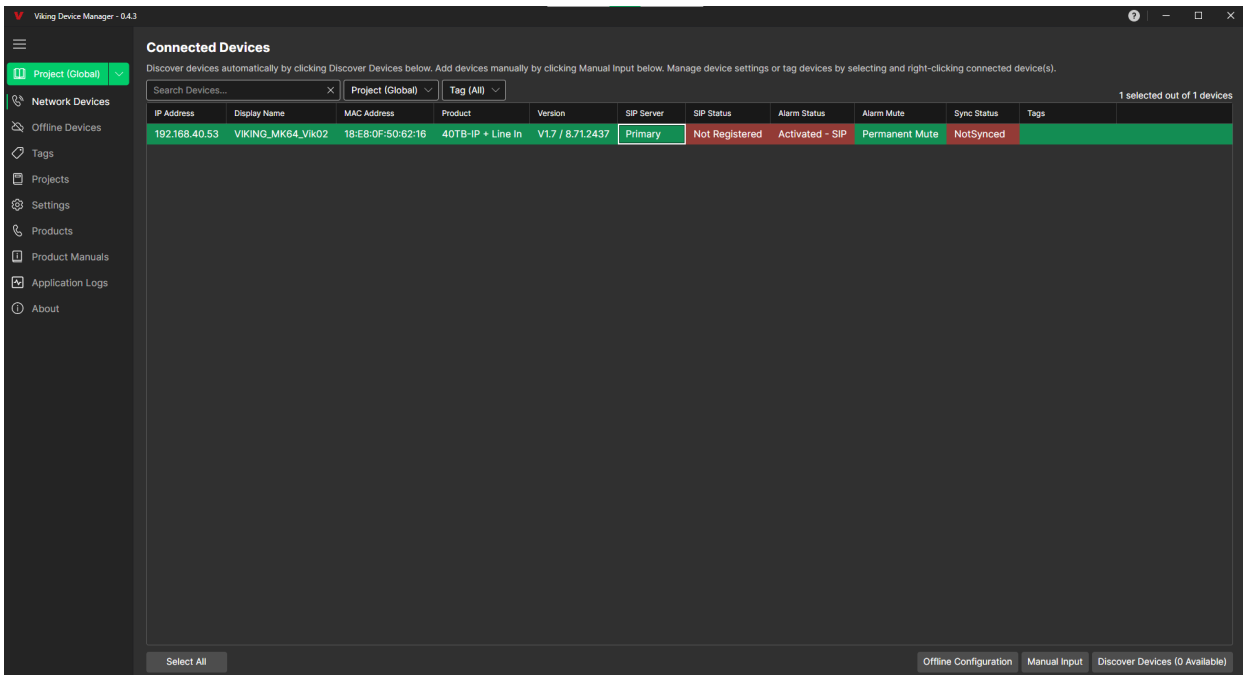

B. Configuring the E-1600-IP Network Settings (Single Device)

Step 1.	The Connected Devices window shows all units actively connected. Select a unit from the list by clicking on it.
Step 2.	Right-click on the unit, then select 'Configure->Set IP Settings'.
Step 3.	Set the IP Mode to DHCP or Static. For a Static IP set the Subnet Mask, Gateway, and DNS Server Addresses as well.
Step 4.	Review any changes to make sure the IP settings are correct.
Step 5.	Click on Save IP Settings to apply changes and reboot the device. If the box is checked to re-connect the software it will connect again once rebooted.

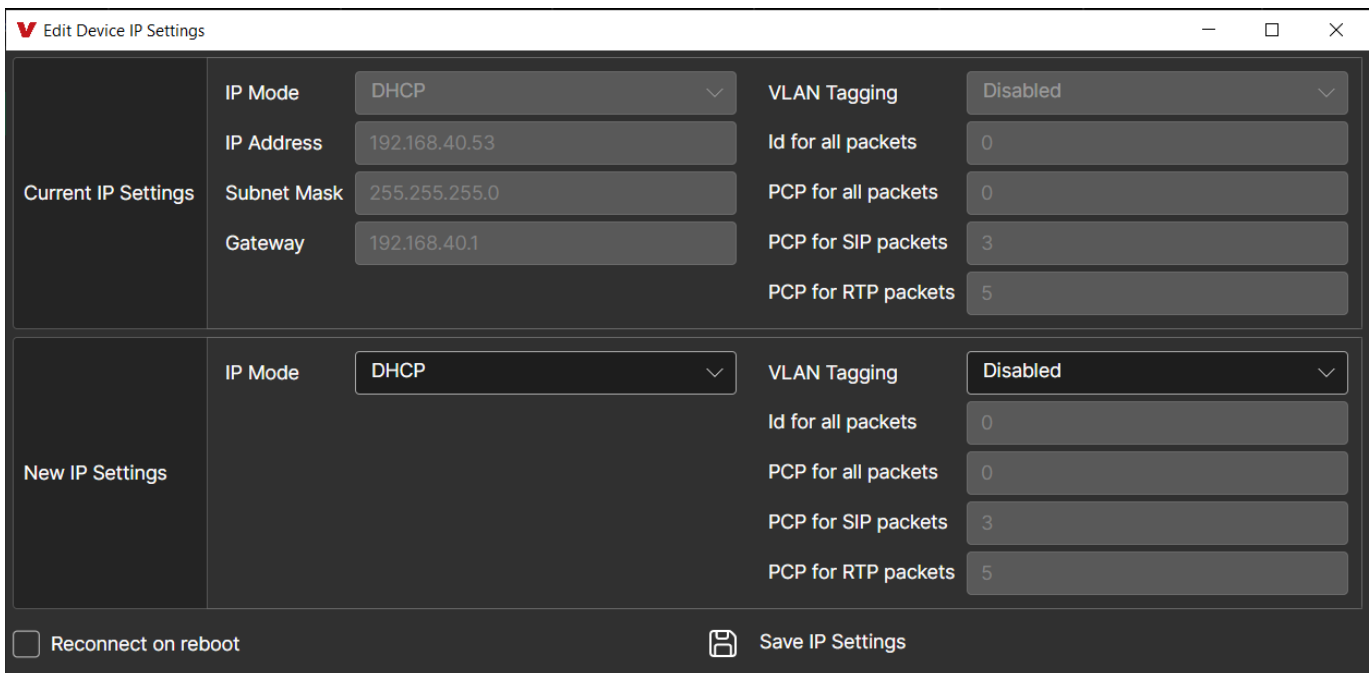

C. Configuring the E-1600-IP Network Settings (Multiple Devices)

Step 1.	The Connected Devices window shows all units actively connected. Select a group of units from the list.
Step 2.	Right-click on the group, then select 'Configure->Set IP Settings'.
Step 3.	Set the IP Mode to DHCP or Static. For a Static IP set the Subnet Mask, Gateway, and DNS Server Addresses as well.
Step 4.	Multiple Static IP Addresses are assigned using a range. This supports "*" and "-" to declare a range e.g. "192.168.40.*" (for 192.168.40.1-192.168.40.255) or "192.168.40.5-10" (for 192.168.40.5-192.168.40.10).
Step 5.	Click on "Next" to test the address range and review changes.
Step 6.	Click on Save IP Settings to apply changes and reboot all device. If the box is checked to re-connect the software it will connect again once rebooted.

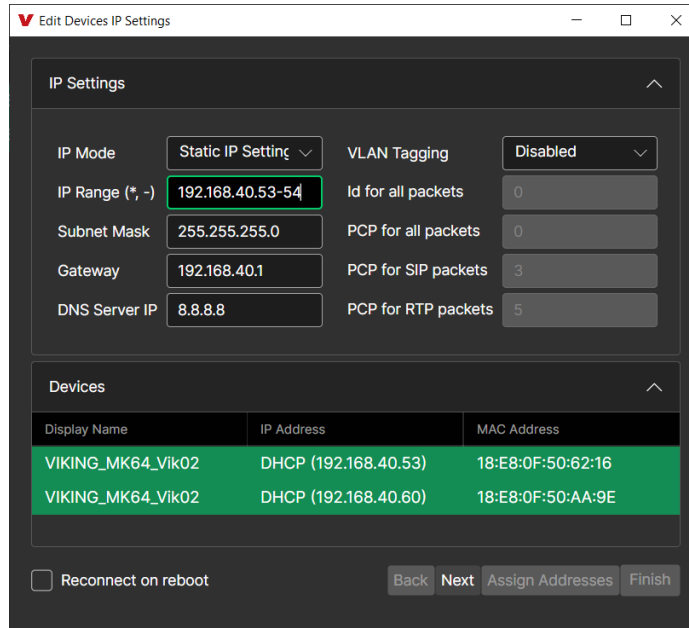

D. Configuring E-1600-IP VLAN Settings

The VLAN settings can be set at the same time as the IP Settings, or from the Configure Devices page. Select a connected unit and right-click on it. Select "Configure->Settings", then type "VLAN" into the search box or scroll down to view/modify the parameters.

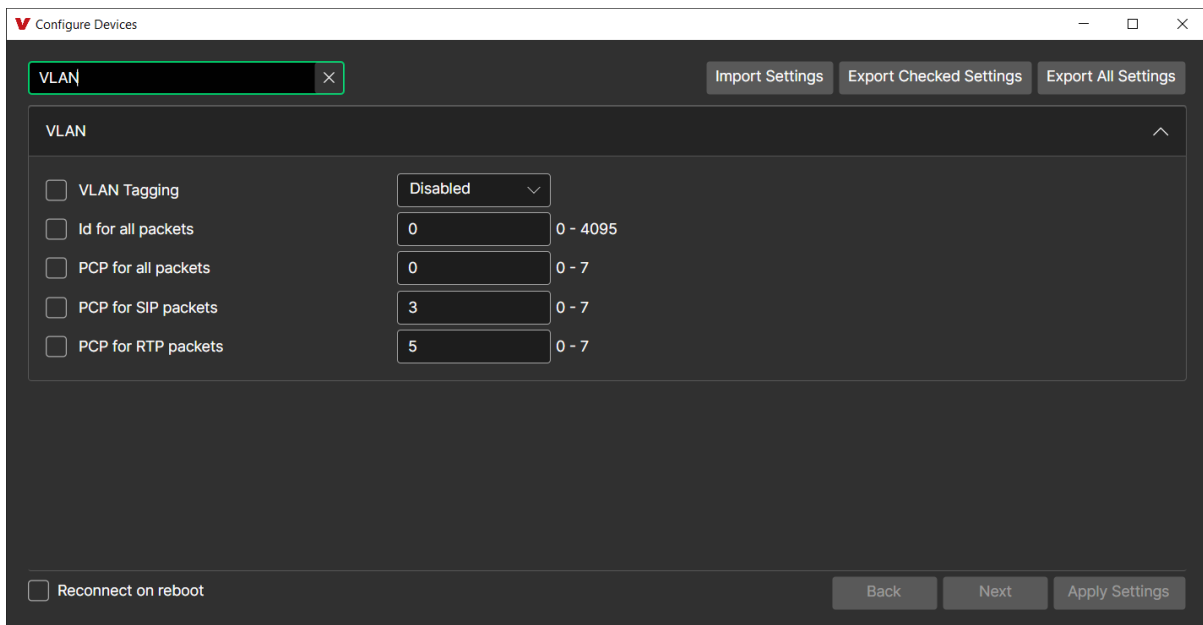

E. Manually Resetting the Security Code to Enter Programming

Note: This procedure will not erase a username and password used to access the E-1600-IP program mode. Only the security code is set to default.

Step 1.	Power down the 1600-IP Series phone by disconnecting the LAN Cable (RJ45 plug).
Step 2.	Press and hold the Call button, then reconnect the LAN Cable (RJ45 plug).
Step 3.	Continue to hold Call button until you hear 2 beeps, (approximately 12 seconds). Then release the button. The LED will remain ON for the first 8 seconds, flash slowly for 4 seconds then fast flash (after 2 beeps), indicating when to release button.
Step 4.	The security code is now reset to 845464 (factory default).
Step 5.	You can now enter programming by following the steps in section A .

F. Manually Resetting All Parameters to Factory Default (IP and phone settings back to default. Phone numbers, paging sources and audio files erased.)

Note: This procedure will erase a username and password that are used to access the E-1600-IP program mode.

Step 1.	Power down the 1600-IP Series phone by disconnecting the LAN Cable (RJ45 plug).
Step 2.	Press and hold the Call button, then reconnect the LAN Cable (RJ45 plug).
Step 3.	Continue to hold the Call button until you hear 2 beeps, (approximately 12 seconds). Continue to hold Call button until you hear 4 more beeps, approximately 6 seconds later, then release the button. The LED will remain ON for the first 8 seconds, flash slowly for 4 seconds (2 beeps), fast flash for 6 seconds (4 beeps), then light steady indicating when to release button.
Step 4.	You can now enter programming by following the steps in section A .

Programming Features Index

DESCRIPTION	Section	Page
Discover and Connect	A	25
VLAN Settings	D	27
Device Name	1	30
SIP Server	2	30
Peer to Peer Settings	3	30
Outbound Proxy	4	30
Authentication ID	5	30
Register Fails (Re-Resolve or Alternate Server)	6	31
Pre Page Tone	7	31
Multicast Page Length Timeout (1 - 255 seconds, factory set to 180 seconds)	8	31
Multicast Page Type	9	31
SIP Page / Call Priority vs Multicast	10	32
Multicast Paging	11	33
Multicast Paging Volume (0 - 19, factory set to 1)	12	33
Emergency Phone Numbers and Information Phone Numbers	13	33
Security code (factory set to 845464)	14	33
ID Number	15	34
Access Code (1 - 6 digits, blank = disabled, factory set to 123456)	16	34
Internal / External Relay (factory set to Internal)	17	34
Relay Mode (Door Strike, Outbound Call, Inbound / Outbound Call, Doorbell, LV-1K Control, Ring, Ring Flash, factory set to Outbound Call)	18	35
Relay Activation Command (1 or 2 digits, factory set to **) Note: <i>Relay Mode must be set to Door Strike</i>	19	35
Relay Activation Time (0.5 - 99 sec, factory set to 5 sec)	20	35
Relay Buzz Volume (1 - 3 or Disabled, factory set to 2)	21	35
Relay Latch Commands (Enabled or Disabled, factory set to Enabled) Note: <i>Relay Mode must be set to Door Strike</i>	22	35
Speaker Mode (ON, OFF / Silent Monitor or OFF until Answered, factory set to ON)	23	36
Speaker Volume (0 - 19, factory set to 7)	24	36
Alternating Switch Action (factory set to Enabled)	25	36
Ring Volume (0 - 19, factory set to 5)	26	36
Microphone Volume (Auto, 1 - 9, factory set to 5)	27	36
Talk/Listen Delay (VOX) (0.1 - 0.9 seconds, factory set to 0.5 seconds)	28	36
In-Band Audio Call Progress (Enabled, Disabled, factory set to Enabled)	29	36
In-Band Detect Sensitivity (1 - 9, 1 = minimum, 9 = maximum, factory set to 5, power cycle unit after setting)	30	36
Repeat Announcement Option (factory set to 1)	31	36
Lap Counter (1 - 9 or Disabled, factory set to Disabled)	32	37
Call Length Timeout (disabled or 1 - 9 minutes, factory set to 3 minutes)	33	37
Inbound Call Mode (Disabled, Auto Answer, Auto Answer-Secure, Ring, Ring with AGC, Factory set to Auto Answer)	34	37
Ring Cadence (factory set to Normal Ring, 2 seconds on 4 seconds off)	35	37
Redial on Ring No Answer (disabled, 1 - 9 = number of rings, factory set to 7)	36	37
Dial Next Number on Busy (disabled or enabled, factory set to enabled)	37	38
Send ID Number as (RFC 2833 or In Band DTMF, factory set to RFC 2833)	38	38
"Call" LED Mode (OFF, Entry Phone, Emergency Phone or Emergency Outbound only, factory set to Emergency Phone)	39	38
"Call" LED Control (Automatic or enter * to light, factory set to Automatic)	40	38
Mute Current / Next Alarm	41	38
Permanent Alarm Mute (factory set to Enable Alarm Beeps)	42	38
Programming a Username and Password to Restrict Access to Programming	43	39
Firmware Updates	44	40
Import/Export	45	40

DESCRIPTION	Section	Page
Reset PIC Settings	46	40
Reset IP Settings	47	40
Audio File	48	40
Recording Emergency Announcement from a phone	49	40
Diagnostics (used to check mic, speaker and relay operations)	50	40

Programming Features

1. Device Name

A unit name up to 31 characters in length can be assigned to the **1600-IP Series** Phone being programmed.

2. SIP Server

Enter the IP address or URL of your SIP server or service provider in this field. The SIP server IP address is limited to 74 characters. **Note:** *If an alternate SIP server IP address is programmed, the IP address for the SIP server and alternate SIP server will be limited to 31 characters.*

3. Peer to Peer Settings

When set to the Peer to Peer mode, a SIP server is not used, the **1600-IP Series** phone will register to itself. Applications for the Peer to Peer mode are very limited, as the **1600-IP Series** phone is only able to call other IP phones or SIP devices that are on the same LAN. The **1600-IP Series** phone can not call analog extensions, digital phone extensions, telephone numbers that are outside the phone system or another handsfree Viking IP device in this mode (see note below). To use the unit in the Peer to Peer mode, change the drop-down in the “SIP Server / Peer to Peer Settings” from “Server” to “Peer to Peer”, a Username must be assigned (can be any alpha/numeric string up to 31 characters) and the unit should be programmed with a static IP address. Here is an example to show how the calling process works:

	E-1600-IP	Destination IP Phone
IP Address	192.168.210.1	192.168.210.3
Extension Number	N/A	200
Username	Viking1	N/A

E-1600-IP calling the IP phone – you populate the first phone number field with 200@192.168.210.3 (the extension number you are trying to call + @ + the IP address of the extension you are calling).

The IP phone calling the **1600-IP Series** Phone– a button on the IP phone is configured to dial Viking1@192.168.210.1 (the Username assigned in the **1600-IP Series** Phone + @ + the IP address of the **1600-IP Series** phone).

- Notes:**
1. *A Viking handsfree IP Device calling another Viking handsfree IP Device is not recommended.*
 2. *Peer to Peer mode does not affect multicast paging.*

4. Outbound Proxy

If your SIP provider requires an outbound proxy IP address enter it in the Outbound Proxy field. **Note:** *If not required, leave this field blank.*

5. Authentication ID

If your SIP provider requires Authentication ID, enter it in the Authentication ID field. If Authentication ID is not required, leave this field blank.

6. Register Fails (Re-Resolve or Alternate Server)

When registered to a SIP server you can program the unit to re-resolve using the current SIP server IP address or route pages through an alternate SIP server in the event that registration is lost. With Alternate Server selected enter the IP address of the alternate SIP server in the field next to the Register Fails drop down box. Add an Alternate Proxy address as well if Proxy is used. When Registration Fails is set to Re-Resolve or Alternate Server, the unit will reboot after two Minutes and Fifty seconds of SIP / Network Alarm. Alternate Server mode alternates between primary and alternate servers each reboot. **Note:** With an alternate SIP server IP address programmed, the IP address for the SIP server and alternate SIP server will be limited to 31 characters.

Standard

multicast

Import Settings Export Checked Settings Export All Settings

Multicast Settings

Pre Page Tone Enabled

Multicast Page Length Time Out 180 0 - 255 seconds (0=disable)

Multicast Page Type Standard

Incoming SIP Call Priority 0

Outgoing SIP Call Priority 0

Multicast Paging Source 0 IP (224.0.0.1-239.255.255.255) Port (8008) Volume 1 Timeout

Multicast Paging Source 1 IP (224.0.0.1-239.255.255.255) Port (8008) Volume 1 Timeout

Multicast Paging Source 2 IP (224.0.0.1-239.255.255.255) Port (8008) Volume 1 Timeout

Multicast Paging Source 3 IP (224.0.0.1-239.255.255.255) Port (8008) Volume 1 Timeout

Multicast Paging Source 4 IP (224.0.0.1-239.255.255.255) Port (8008) Volume 1 Timeout

Multicast Paging Source 5 IP (224.0.0.1-239.255.255.255) Port (8008) Volume 1 Timeout

Multicast Paging Source 6 IP (224.0.0.1-239.255.255.255) Port (8008) Volume 1 Timeout

Multicast Paging Source 7 IP (224.0.0.1-239.255.255.255) Port (8008) Volume 1 Timeout

Multicast Paging Source 8 IP (224.0.0.1-239.255.255.255) Port (8008) Volume 1 Timeout

Reconnect on reboot

Back Next Apply Settings

7. Pre Page Tone

When enabled, a short beep will be heard prior to SIP or Standard Multicast paging audio. The volume of the Pre Page Alert Tone will match the volume setting of the SIP or Standard Multicast page. **Factory Setting:** Enabled

8. Multicast Page Length Timeout

The Multicast Page Length Timeout can be programmed from 1 - 255 seconds in one second increments. The Time Out can be disabled, allowing any length of page or continuous background music. Only one timeout time can be programmed for all multicast paging groups. When using standard Multicast Paging, a timeout checkbox can be selected for each paging group. When using Polycom Multicast Paging, the timeout checkbox enables the timeout globally on groups 1 through 24. There is no timeout for a page to the emergency group 25.

Factory Setting: 180 seconds

9. Multicast Page Type

Select Standard or Polycom as the source of multicast paging. If Polycom is selected as the source, the screen will change to show its options (see next page).

Factory Setting: Standard (shown above)

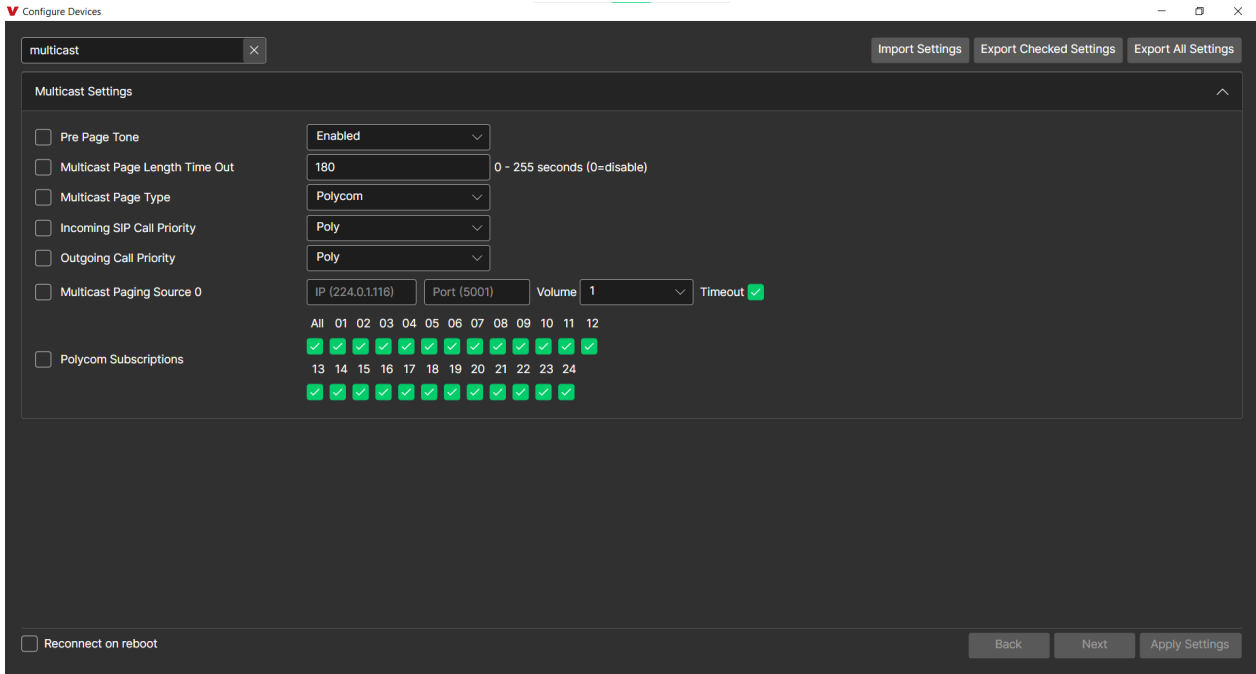

10. SIP Page / Call Priority vs Multicast

Incoming and outgoing non-emergency SIP call audio streams can be programmed to have priority over any of the 10 Standard multicast paging groups. Use the “Incoming SIP Call priority” and “Outgoing Call priority” drop down menus to select which multicast groups you want SIP calls to have priority over. “Incoming SIP Call priority” is to set the priority of incoming SIP pages and “Outgoing Call priority” is to set the priority of outgoing non-emergency SIP calls. Regardless of the priorities selected, outgoing SIP emergency calls have the highest priority and will interrupt any multicast source. **Factory Setting for both:** 0 (SIP is highest priority)

When Polycom is selected as the Multicast Page Type, the “Incoming SIP Call priority” and “Outgoing Call priority” can be set to “Poly” or “None”. See the following tables for the order of priorities with each setting. As shown, outgoing SIP emergency calls have the highest priority and Polycom Group 25 multicast has the second highest priority. The priority options allow you to determine the priorities for Polycom Groups 1 through 24 multicast signals, SIP paging and non-emergency outbound SIP calls. **Factory Setting for both:** Poly

Paging Priorities (Incoming SIP Call Priority and Outgoing Call Priority both set to “Polycom”)	Paging Priorities (Incoming SIP Call Priority and Outgoing Call Priority both set to “None”)
Emergency Outbound SIP Calls	Emergency Outbound SIP Calls
Polycom Group 25	Polycom Group 25
Non-emergency Outbound SIP Calls and SIP paging	Polycom Groups 1-24
Polycom Groups 1-24	Non-emergency Outbound SIP Calls and SIP paging
Line In Audio Source	Line In Audio Source

Paging Priorities (Incoming SIP Call Priority set to “None” and Outgoing Call Priority set to “Poly”)	Paging Priorities (Incoming SIP Call Priority set to “Poly” and Outgoing Call Priority set to “None”)
Emergency Outbound SIP Calls	Emergency Outbound SIP Calls
Polycom Group 25	Polycom Group 25
Non-emergency Outbound SIP Calls	SIP Paging
Polycom Groups 1-24	Polycom Groups 1-24
SIP Paging	Non-emergency Outbound SIP Calls
Line In Audio Source	Line In Audio Source

11. Standard or Polycm Multicast Paging

Standard

When using standard Multicast Paging, up to 10 multicast paging groups can be programmed into each **1600-IP** phone. Each multicast group is defined by a multicast address and port number. Each multicast group is assigned a priority, allowing simultaneously arriving pages to be serviced based on importance. A timeout check box can be selected for each paging group. See “Multicast Page Length Time Out” under “Multicast Settings” to adjust the timeout from 1 - 255 seconds. Only one timeout time can be programmed for all groups. The volume for each multicast group can be programmed separately.

Assigning Priority to standard Multicast Paging

The **1600-IP** will prioritize simultaneous audio streams according to their priority in the Paging Sources list. Group 0 will have the highest priority while group 9 will have the lowest priority. Group 9 is useful for a low priority stream such as background music. Group 0 is useful for high priority streams such as emergency messages.

The multicast paging groups can also be used for up to ten different paging zones for receiving audio streams. A paging zone can consist of one or many **1600-IP** multicast phones. There is no limit to how many speakers can be in a given paging zone.

Polycom

Polycom IP phones send multicast audio to a specific IP address and port. A total of 25 groups can be used, with group 25 generally reserved for an emergency broadcast. Set the Multicast Page Type to “Polycom”. The Viking Device Manager will then show “Polycom Settings”. Polycom phones will default to IP address 224.0.1.116 and port 5001 for multicast. Under “Polycom Subscriptions”, enter the IP address and port you chose in the Polycom IP phone as “Multicast IP address” and “port” (Paging/PTT Configuration page). Select the paging groups the **1600-IP** should subscribe to. Any multicast audio sent to the correct IP address, port number and a subscribed group will be heard from the Speaker. Group 1 is the lowest priority and group 25 is the highest. The Volume and Timeout can be selected globally, although the timeout does not affect group 25. **Factory Setting:** all Groups selected

12. Multicast Paging Volume

The volume of each individual standard multicast page can be adjusted from 0 - 19. When polycom paging is used, the paging volume is set globally for all 25 groups. **Factory Setting:** 1

13. Emergency Phone Numbers and Information Phone Numbers

Note: Up to 64 digits can be stored in each of the 5 information phone number and 5 emergency phone number positions. The phone number dialed when the call button is pressed depends on the programming of the Alternating Switch Action.

Emergency Phone Numbers

The number programmed in the first location under “Emergency Phone Numbers” is the first telephone or extension number that is dialed when the call button is pressed. Additional numbers (if programmed) will be dialed when there is no answer and the Dial Next No. on Ring No Answer feature is enabled. The **1600-IP Series** phone will also detect busy and move on (Dial Next Number on Busy Enabled). The **1600-IP Series** phone will cycle through the programmed emergency numbers until answered. Additional numbers (if programmed) will be dialed when there is no answer and the Dial Next No. on Ring No Answer feature is enabled. If a recording is uploaded it will play after the line has been answered and can be repeated when a touch tone “*” is entered.

Information Numbers (1600-20/22/52/53-IP only)

The number programmed in the first location under “Information Phone Numbers” is the first telephone or extension number that is dialed for a non-emergency call. Additional numbers (if programmed) will be dialed when there is no answer and the Dial Next No. on Ring No Answer feature is enabled. The **1600-IP Series** phone will cycle through the programmed phone numbers until answered. The **1600-IP Series** phone will also detect busy and move on (Dial Next Number on Busy Enabled). **Note:** The voice recording will not play when Information Numbers are dialed.

14. Security Code

The security code allows the user/installer to program the **1600-IP Series** phone with a PC and the required ‘Viking Device Manager’ software. If the security code is left as default, the PC software won’t require entering a security code when connecting to the **1600-IP Series** phone. It is recommended that the factory set security code be changed. The security code can be set back to default by holding the CALL button while the **1600-IP Series** phone powers up. See Programming section E for details. **Factory Setting:** 845464

Note: The security code must be 6 digits and cannot include a * or a #.

15. ID Number:

The ID Number (1 - 6 digits) is used by emergency personnel to identify the location of the caller and is given out when the receiving party presses a “*”. This ID number can be transmitted as RFC 2833 (Factory Setting) or In-Band DTMF. This can be cleared out by leaving the field blank. **Factory Setting:** 987654

16. Access Code

The Access Code is used for remotely operating the relay (Doorstrike, Mag-Lock, etc) by calling into the unit. This code provides basic security and only allows operation of the relays and not the ability to change any of the programming parameters. Once entered, any of the “Remote Access Operation Commands” can be used. Simply call the **1600-IP Series** phone (set to auto-answer/auto-answer secure), the unit will automatically answer the line and output one beep. You then enter the programmed 1 - 6 digit access code, 2 beeps should be heard. You can now enter any “Remote Access Operation Commands” (see Operation section D). This code will also enable audio to / from the speaker and the caller. The access code can be cleared (by leaving the field blank) if this additional level of security is not required. **Factory Setting:** 123456

Note: The Access Code can be 1 - 6 digits in length and cannot include a * or # or match the numbers used for the Security Code.

Configure Devices

Relay

Import Settings Export Checked Settings Export All Settings

Speaker Settings

- Internal / External Relay Internal
- Relay Mode Outbound Call
- Relay Activation Command **
- Relay Activation Time 5 seconds
- Relay Buzz Volume 3
- Relay Latch Commands Enabled

Reconnect on reboot

← Back Next → Apply Settings

17. Relay Internal / External

With the relay set to “Internal” the **E-1600-IP Series** phone will activate its on board relay for door strike / gate control. The Relay should be set to “External” for higher security installations when using a Viking remote model **RC-4A** relay controller to activate the door strike / gate controller. **Factory Setting:** Internal

18. Relay Mode

Door Strike Mode: When programmed for Door Strike Mode the relay will momentarily activate for the preprogrammed relay activation time after detecting the correct relay activation command (one or two digit touch tone) from the called party.

Outbound Call Mode (Factory Setting): When programmed for Outbound Call Mode the relay will activate continuously for the duration of any outbound call from the Emergency/Entry phone. This mode is useful for activating strobe lights for Emergency VoIP phones.

Phone / Paging Mode: When programmed for Phone / Paging Mode the relay will activate continuously for the duration of any SIP or multicast page or any inbound or outbound call to or from the Emergency/Entry phone. This mode is useful for turning on IR flood lights, VoIP phones with cameras, etc.

Doorbell Mode: When programmed for Doorbell Mode the emergency / entry phone will momentarily activate the relay for the preprogrammed relay activation time on any outbound call from the emergency / Entry phone. This mode is useful for activating a door chime, etc. When activating door chimes, a 0.5 - 1 second relay activation time is recommended.

Alarm Mode: When programmed for Alarm Mode the relay will activate continuously while the Emergency / Entry phone is powered and registered to the SIP server. In the event the unit loses power and/or SIP registration the relay will turn off. The relay can be used to activate the **LV-1K's** flashing LED and audible beep signals.

Ring Mode: When programmed for Ring Mode the relay will continuously activate while the ringing extension is called. Inbound call Mode must be "Ring" or "Ring with AGC". This mode is useful for activating a Viking model **SL-2** strobe light, etc.

Ring Flash Mode: When programmed for Ring Flash Mode the relay will momentarily turn on and off in a 400ms on/off cadence while the ringing extension is called. Inbound call Mode must be "Ring" or "Ring with AGC". This mode is useful for activating a Viking **LPL-1** Remote Visual Indicator, etc.

19. Relay Activation Command

The one or two digit code stored in the Relay Activation Command is the touch tone command that the person being called must enter on their phone in order to momentarily activate the relay to control a doorstrike, mag-lock, gate controller, or other device. The code can contain the characters 0 - 9, # or *. The code cannot match a relay latching command (*1, *0). The code must be entered while the remote phone is communicating with the Speaker phone.

Factory Setting: **

20. Relay Activation Time

The value stored in the Relay Activation Time is the amount of time the relay will be energized after a correct momentary touch tone command is entered. This number can range from 0.5 - 99 seconds. This also affects timing in Doorbell Mode. **Factory Setting:** 5 seconds

21. Relay Buzz Volume

The relay activation tone is a buzzing sound that is heard from the speaker when the door strike relay is activated. After the called party enters the correct relay activation command, the called party will hear 2 short confirmation beeps and the entry phone will output a buzzing sound (relay activation tone) while the door strike relay is activated. The tone (buzz) length will match the relay activation time up to a maximum of 5 seconds. The tone (buzz) can be programmed to three different volume settings 1 = Low, 2 = Medium, 3 = High or it can be disabled. **Factory Setting:** 3

22. Relay Latch Commands

When set to "Enabled" the Remote Access Operation Commands (*0 to *1) to Un-Latch or Latch the relay are enabled. These can be entered on a Inbound call after the access code is dialed (if programmed).

When set to "Disabled" the Remote Access Operation Commands (*0 to *1) to Un-Latch or Latch the relay are disabled. Disabling the Latch commands can be useful in applications where you want to eliminate the possibility of inadvertently entering a latch command leaving a gate open/closed, etc. **Factory Setting:** Enabled

23. Speaker Mode

The Speaker Mode can be set to one of the following three modes. **Factory Setting:** On

Off / Silent Monitor Mode: In the “Off / Silent Monitor” mode the speaker is disabled at all times. However, the speaker can be enabled after communication has been established by entering touch tone command “9#”. The speaker will remain on for the duration of the call.

On (Factory Setting): In the “On” mode the speaker is enabled during In-bound and Out-bound calls.

Off Until Answered: In the “Off Until Answered” mode the speaker will remain silent during dialing and will not turn on until the called party has answered.

24. Speaker Volume

The Speaker volume can be set from 0 - 19. 0 = lowest volume setting, 19= highest volume setting. Adjusting this will set the Speaker volume level for SIP Paging and incoming/outgoing phone calls. This setting does not affect multicast volume settings. **Factory Setting:** 7

The Speaker volume can alternatively be set to Auto 0 – 10, 15 or 19. 0 = the lowest automatic volume setting and 10, 15 or 19 = the highest automatic volume setting. With volume set to auto the **1600-IP Series** phone will use its built-in microphone to monitor background room noise and automatically increase or decrease the Speaker and Line Out volume for SIP paging, incoming/outgoing phone calls and Multicast paging. **Note:** *The minimum volume setting for multicast paging is set separately per multicast IP address and port. See “Paging” menu in Viking Device Manager*

25. Alternating Switch Action (Panic Button Mode)

With Alternate Switch Action Enabled the CALL button alternately connects and disconnects calls. With Alternate Switch Action Disabled the CALL button connects calls only. Pressing the button again after the call has been initiated will not terminate the call. **Factory Setting:** Enabled

26. Ring Volume

When set to Ring or Ring with AGC, the **1600-IP Series** phone will output a loud ring when it is called. The level can be adjusted from 0 - 19. **Factory Setting:** 5

27. Microphone Volume / Automatic Noise Cancelling Mode

The microphone volume can be set from 1 to 9, 1 = lowest volume setting, 9 = highest volume setting. Alternatively the microphone can be placed in the “Auto” Automatic Noise Cancelling mode. With the mic in the Auto mode, when background noise increases, the mic gain will automatically decrease. When background noise decreases the mic gain will automatically increase. The Auto mode is useful in applications where the background noise level can change drastically. **Factory Setting:** 5

28. Talk / Listen Delay (VOX)

This feature selects switching time between talk and listen modes (VOX switching time). The Talk/Listen Delay can be programmed from 0.1 - 0.9 seconds. **Factory Setting:** 0.5 seconds

29. In-Band Audio Call Progress

The In-Band Audio Call Progress Detection can be set to enabled or disabled. In-Band Audio Call Progress detection should be enabled in applications where you are making an outbound call through your VoIP phone system and are relying on In-Band analog audio for ringback or busy detection. **Factory Setting:** Enabled.

30. In-Band Detect Sensitivity

The In-Band Audio Detection level (Sensitivity) can be set from 1 - 9, 1 = minimum setting, 9 = highest setting. Increasing or decreasing the sensitivity may be required in applications where you are making an outbound call through your VoIP phone system and are relying on In-Band analog audio detection. **Factory Setting:** 5

31. Repeat Announcement Option

The **1600-IP Series** phone can be programmed to play the announcement from 1 - 9 times, or to continuously repeat the announcement every 6 seconds until a Touch Tone “*” is detected from the distant party. The call connected LED will turn on automatically after the announcement has stopped repeating.

Factory Setting: 1 (play the announcement 1 time)

32. Lap Counter

With the lap counter disabled, if the **E-1600-IP Series** phone is programmed to dial the next number on ring-no-answer and/or busy signal, the **E-1600-IP Series** phone will continuously call its programmed phone numbers forever until the call is answered.

The lap counter is a programmable counter that determines how many times the **E-1600-IP Series** phone will cycle through its list of up to 5 emergency phone numbers, before it stops the dialing process and hangs up. When all of the programmed phone numbers have been dialed, the lap counter is incremented and the dialing process repeats. When the lap counter has been met, the dialing process stops and the **E-1600-IP Series** phone hangs up.

Factory Setting: Disabled

33. Call Length Timeout

This feature selects the maximum length of time that calls can be connected. Programmable in increments of 1 minute up to a maximum of 9 minutes or disabled. With the call length disabled, the **1600-IP Series** phone must rely on a call ended signal, busy signal, Ring No Answer limit, or touch tone # to hang-up. **Factory Setting:** 3 minutes

34. Inbound Call Mode

The Inbound Call Mode determines how the **1600-IP Series** phone handles incoming SIP calls. One option is to generate a loud ring sound through the speaker. The **1600-IP Series** phone can also auto answer a SIP call to transmit a page, control the relay or listen to transmit audio from the microphone. The “secure” option for auto answer requires the caller to dial the access code in order to transmit a page or activate the relay. **Factory Setting:** Auto Answer

Disabled – Inbound SIP calls are not allowed.

Auto Answer – Inbound SIP calls are auto answered on the first ring. This can also be used for Silent Monitoring by changing the Speaker Mode to ‘OFF/Silent Monitor’. For more security use the Auto Answer Secure Mode.

Auto Answer Secure – In the “Auto Answer - Secure” mode, the phone will automatically answer an incoming call on the first ring. The unit will then output 2 beeps but will not go into two-way voice mode. After the 2 beeps are heard, you will have 10 seconds to enter the pre-programmed 1 - 6 digit Access Code. When the correct code is entered, 2 beeps will be heard and the unit will enable the Two-Way Mode (mic and speaker audio). After the correct Access Code is entered, any of the “Remote Access Operation Commands” can be used (see Operation, section D). **Note:** *If the wrong Access Code is entered or more than 10 seconds have elapsed, the phone will output 3 beeps and disconnect.*

Ring: In the “Ring” mode the **1600-IP Series** phone will not automatically answer an incoming call but will output a loud ring signal out of the speaker in a 2 seconds on, 4 seconds off ring pattern. There are four available ring cadences. The call can then be answered by momentarily pressing the call button.

Ring with AGC: In the “Ring with AGC” mode the **1600-IP Series** phone will not automatically answer an incoming call but will output a loud ring signal out of the speaker in a 2 seconds on, 4 seconds off ring pattern. The phone will automatically increase or decrease the ring volume based on background ambient noise. The call can then be answered by momentarily pressing the call button.

35. Ring Cadence

The Ring cadence can be programmed to one of four different cadences. **Factory Setting:** Normal Ring

Normal Ring (single ring, 2 seconds on 4 seconds off) factory setting

Double Ring (double ring, 1 second on 0.5 seconds off 1 second on 3.5 seconds off)

Short-Short-Long (triple ring, 0.5 seconds on 0.5 seconds off 0.5 seconds on 0.5 seconds off 1 second on 3 seconds off)

Short-Long-Short (triple ring, 0.5 seconds on 0.5 seconds off 1 second on 0.5 seconds off 0.5 seconds on 3 seconds off)

36. Dial Next Number on Ring No Answer

If enabled and a ring-no-answer is detected, the **1600-IP Series** phone will dial the next programmed phone number after the programmed amount of rings.

Factory Setting: 7 (will redial after 7 rings)

37. Dial Next Number on Busy

If enabled and a busy is detected, the **1600-IP Series** phone will dial the next programmed phone number.
Factory Setting: Enabled

38. Send ID Number as

The I.D. number can be transmitted as RFC 2833 or as In-Band DTMF. **Factory Setting:** RFC 2833

39. “Call” LED Mode

The “Call” LED on the **E-1600-IP Series** can be programmed to one of four different modes.

Factory Setting: Emergency Phone

Off Mode: Useful for silent monitoring applications. In this mode the LED will not light during normal operation. It will only light (blink) if it cannot register with the programmed SIP server or while manually resetting all network parameters to factory default.

Entry Phone Mode: The LED will remain ON in the idle state, turn off while button is pressed, blink during dialing, light steady when the call is answered, then turn OFF momentarily when the call is completed.

Emergency Phone Mode: The LED will remain OFF in the idle state, blink during dialing, light steady when the call is connected, then turn OFF when the call is completed.

Emergency Phone Outbound Only: On outbound calls, the LED will remain OFF in the idle state, blink during dialing, light steady when the call is connected, then turn OFF when the call is completed. On in-bound calls, the LED will remain off. This is useful for silent monitoring on inbound calls.

40. “Call” LED Control

During outbound SIP calls the “CALL” LED can be programmed to light automatically when the called party has answered or only light after the called party has entered a touch tone “*”. **Factory Setting:** Automatic

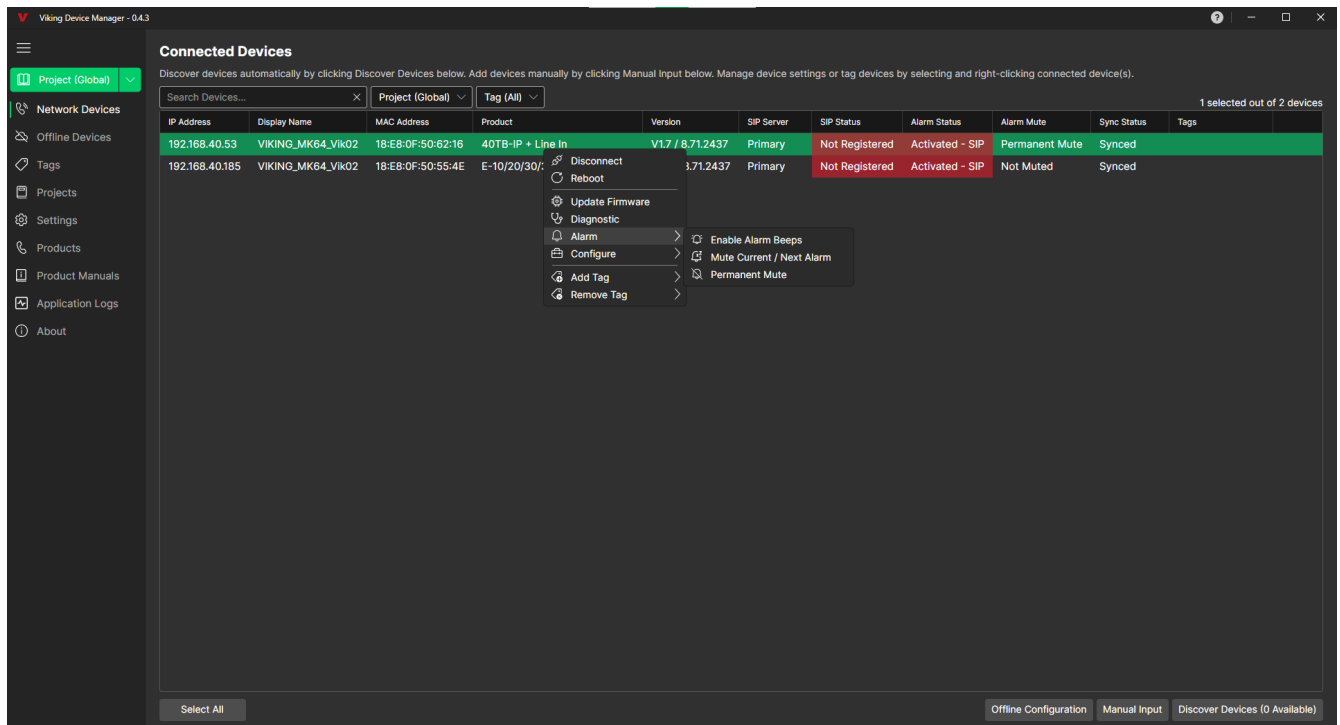

41. Mute Current / Next Alarm

A network failure alarm will be indicated by providing 3 beeps every 30 seconds. A network failure indicates the unit is not registered to the SIP server or there is a communication failure with the gateway. The three beeps can be muted by choosing “Mute Current / Next Alarm”. The Status LED will continue to flash to assist troubleshooting. The alarm beeps can also be permanently disabled, see Permanent Alarm Mute.

42. Permanent Alarm Mute

Selecting “Permanent Mute” will mute all alarm tones indefinitely. To re-enable alarm tones select “Enable Alarm Beeps”.
Factory Setting: Enable Alarm Beeps

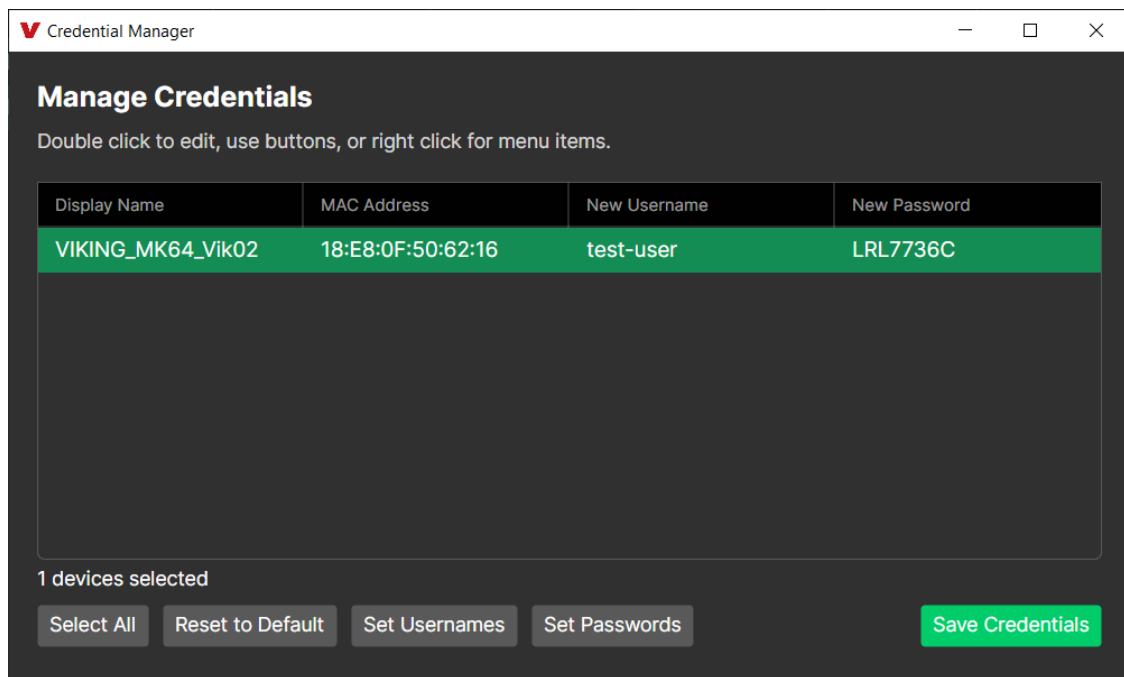
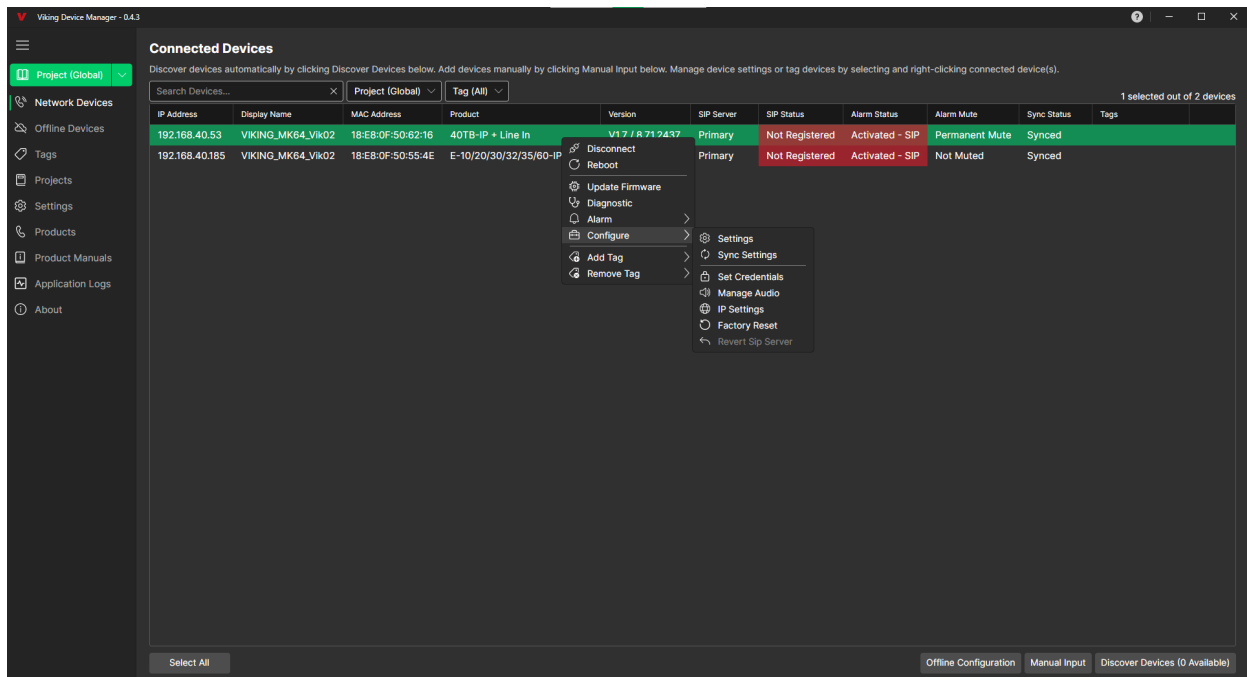

43. Programming Username and Password to Restrict Access to Programming

To increase security, a username and password can be programmed to limit access to the **1600-IP Series** phone using Viking Device Manager software. When no username and password are programmed and the security code is still set to default (845464), the PC software will not require a username, password or security code when connecting to the **1600-IP Series** phone. If the **1600-IP Series** phone has been programmed with a username and password, a pop up window will ask for the username followed by the password. If the unit's security code has been changed from default (845464), it will then prompt for the correct security code.

Setting a Username and Password is highly suggested to secure the device. With Viking Device Manager, the credentials can be encrypted and stored for all devices. These credentials are accessible with the Master password used to authenticate with Viking Device Manager.

If the username and password are unknown, they can only be erased by resetting all network parameters to default with the CALL button (see Programming section F). If the username and password are known but you wish to erase them, that can be accomplished by exporting the data from the **1600-IP Series** phone resetting all network parameters to default with the CALL button (see Programming section F) and then importing the data back into the unit.

44. Firmware Updates

Select one or more units from the list of Connected Devices by clicking on it. Right click and select 'Update Firmware'. A list of connected units is shown and will display the current revisions of firmware. If any columns are red, it indicates the firmware is not up to date and can be upgraded. Select the device(s) you would like to update from the list. Click on either 'Update Unit Firmware' or 'Update IP Firmware' to start the update (firmware files are automatically pulled by the software).

When updating 'Unit Firmware' some settings such as Speaker Volume, Answer Mode, etc. are set to default. The next time the device is connected, 'Not Synced' will be seen. Right click on the device and select 'Migrate Offline Changes' to restore these settings.

45. Import / Export

The Import / Export feature is useful for backing up all the **1600-IP Series** phone's programming or for importing programming when installing multiple units with a majority of the same programming.

46. Reset PIC Settings

"Reset PIC Settings" will reset all of the Programming features back to their factory default settings, including setting the units security code back to the default value (845464).

Note: This command will not change or reset your IP or Multicast paging settings.

47. Reset IP Settings

"Reset IP Settings" will reset all of the IP settings back to their factory default settings. This also clears Multicast IP address / port settings and erases any username and password programmed in the unit to restrict access to programming. **Note:** This will not affect any PIC settings.

48. Audio File (optional)

The **1600-IP Series** Emergency Announcement can be uploaded with any user edited WAV file. Right click on a connected unit and select "Manage Audio" to upload wave files. See "WAV File Guidelines" below. Alternatively the announcement can be recorded via a telephone call (See Recording Emergency Announcement from a Phone). With Viking Device Manager wave files can be uploaded to all **1600-IP** units at the same time.

WAV File Guidelines:

1.	The WAV file should be 8 or 16 bit PCM mono or stereo.
2.	Sampling rates of 8k, 16k or 32kHz are acceptable.
3.	The WAV file may be stereo or multi-channel, but only the Left Channel will be loaded.
4.	When saved, wave files will be converted to 8KHz, mono, 16 bit, PCM.
5.	The internal flash memory can hold up to 28 seconds of recorded audio.

Note: Applications such as Sound Forge, Audacity, and Windows Sound Recorder can be used to create the WAV files.

49. Recording Emergency Announcement from a Phone

Step 1.	Call into the 1600-IP Series with a Touch Tone phone and access programming by entering the security code (845464 is the factory default).
Step 2.	Enter *4, wait for the tone and then begin recording (28 seconds of record time is available).
Step 3.	Enter # to stop the recording. Playback (for reviewing) is automatic.
Step 4.	Enter *5 to review the announcement again.
Step 5.	If you choose to not use a voice announcement, enter *3 to clear the recording.

Example: "Hudson Elementary School, classroom number 216 needs assistance. Press the star key on your telephone to hear this announcement again."

50. Diagnostics

The Diagnostics option in the Viking Device Manager can be used to test the functionality of the mic, speaker and the relay. **Note:** Using the "Test Relay Activation" button is not recommended when Relay Mode is set to Alarm.

A. “HELP” / “CALL” Button

When the “HELP” / “CALL” button is pressed, the **1600-IP Series** phone dials a pre-programmed telephone number. The Call Connected LED momentarily flashes during dialing. In the event the line is busy or there is a ring-no-answer, the unit can be programmed to call additional phone numbers.

The phone then cycles through up to 5 pre-programmed emergency numbers until the call is answered. When the call is answered, the digital voice announcer will automatically play to identify the location of the emergency call. The phones are factory programmed to play the announcement once, and then automatically light the “Call Connected” LED to show that handsfree communication to emergency personnel is established. The * key will send the I.D. number (if programmed), and play the announcement again. The distant party will know the location of the emergency call by either the voice announcement or by decoding the touch tone I.D. number. Once the “Call Connected” LED is on, the # key can be used to force the phone to hang-up.

B. “INFO” Button (E-1600-20/22/52/53-IP)

When the “INFO” button is pressed (**1600-20/22/52/53-IP** only), the phone goes off-hook and dials the first “INFO” phone number programmed. If a busy signal is detected or the call goes unanswered, the phone will cycle through all five “INFO” phone numbers until the call is answered or lap counter is met. When answered, handsfree communication is established. **Note:** *The voice announcement is for **Emergency / Help** calls only and will not play on a call initiated from the “INFO” button.*

C. Multicast

The **1600-IP** can be set to one of two modes for multicasting, Standard or Polycom. Polycom is only used when Polycom IP phones are used. To change to Polycom multicast, go to “Multicast Settings” and change the “Multicast Page Type” to Polycom.

Standard Multicast Paging (Factory Setting)

Up to 10 multicast paging groups can be programmed into each unit and each group is assigned a priority level allowing simultaneous arriving multicast pages to be handled based on importance. Low priority groups are often used for low priority streams like background music and high priority groups are used for high priority streams such as emergency messages. Group 0 is the highest priority, and Group 9 is the lowest. A timeout limit can be set and either enabled or disabled for each multicast group. The volume of each group can be programmed and non-emergency SIP calls can be assigned either higher or lower priority than all or some of the multicast groups. (see SIP Call Priority vs Multicast).

Polycom Multicast Paging

Polycom phones send multicast audio to a specific IP address and port. A total of 25 groups can be used and groups 1 through 24 can individually be enabled/disabled in each **1600-IP**. Group 25 is always enabled, as group 25 is generally used for emergency broadcasts. Any multicast page made from a Polycom phone (on the same LAN) to the programmed IP address, port and to an enabled group will play through the **1600-IP** speaker. The priority of Polycom sources ranges from group 1 (lowest) to group 25 (highest). Non-emergency SIP calls can be assigned either higher or lower priority than Polycom group 1 through 24 multicast paging (see the table in SIP Call Priority vs Multicast for Polycom paging priorities). Multicast page timeout can be enabled/disabled globally for groups 1 through 24 (there is no timeout for group 25) and the length of the Multicast page timeout is adjustable. The volume for Polycom multicast is set globally for all groups.

D. Remote Access Operation Commands

The following commands can be entered after answering an inbound call from the emergency phone. The commands can also be entered on an outbound call to the emergency phone. After the emergency phone auto answers the call, two beeps will be heard. If the access code has been disabled, you can now enter the Remote Access Operation Commands below. If an Access code has been programmed, enter the Access code digits. With the correct code entered, two beeps will be heard and you can now enter the Remote Access Operation Commands below.

Feature	Tone Tone Command	Description
Activate Relay	** or __ __	Momentarily activate relay (1 or 2 digits, factory set to **).
Un-Latch Relay	*0	Un-latch* (deactivate) the relay.
Latch Relay	*1	Latch* (continuously activate) the relay.
Disconnect	#	Disconnects or forces the emergency phone to hang up.
Send ID and Play Message	*	Send ID number (if programmed) and plays the announcement.

* **Note:** Latching commands must be enabled in programming.

Troubleshooting

If the unit cannot register with the programmed SIP server, the LED will blink on and off every two seconds, and three error beeps will be heard every 30 seconds until communication is restored. This alerts a potential user of a problem with the device that will prevent an emergency phone call from being made.

You may silence the error beeps, per instance, by pressing and holding the HELP/CALL button for 5 seconds or by right clicking a device and selecting "Mute Current / Next Alarm" in Viking Device Manager. The error beeps automatically re-enable once the unit is registered, to alert of any new problems that arise.

Line Verification Panel with Key Switch

New ASME A17.1-2010 code requires that “the two-way communications means within the (elevator) car shall include a means to verify operability of the LAN connection”. When your local municipality adopts this new ASME A17.1 code the **LV-1K** can be added to fulfill all requirements for visual and audible signaling when it is determined the LAN connection is not functioning.

The **LV-1K** can be added to any new or existing Viking **1600-IP Series** elevator emergency phone as a stand alone solution. The **LV-1K** continuously monitors for loss of PoE or communication with the server and will immediately provide an audible and visual indication when the LAN connection has been accidentally cut or disconnected.

In accordance to ASME A17.1, the **LV-1K** is labeled “ELEVATOR COMMUNICATION FAILURE” in ¼” high red letters, and will sound an audible signal every 30 seconds and flash a red light when a loss of connection is detected. Authorized personnel can silence the audible signal with the included key switch. The LED will remain flashing until the fault is corrected.



Viking Model LV-1K

Surface or Pedestal Mount Viking Products While Maintaining Weather and Vandal Resistance

The **VE-3x5**, **VE-5x5**, **VE-6x7** and **VE-5x10** add vandal and weather resistance, as well as versatility to many Viking products. The **VE-Series** backboxes are available in black fine texture powder painted steel or Marine Grade 316 stainless steel. The weather resistant boxes are designed to be surface mounted to a wall, post, single gang box, or a **VE-GNP** gooseneck pedestal. **Note: The VE-3x5 is not compatible with the VE-GNP pedestals and is not available in stainless steel.**

The **VE-3x5** is designed to be used with the **E-40-EWP** or **E-50-EWP** Series entry phones. The **VE-5x5** is designed to be used with the **E-10A-EWP**, **E-30-EWP**, **E-30-PT-EWP**, **E-60-EWP**, **E-65-EWP**, **E-70-EWP**, **E-75-EWP** entry phones, the **E-1600-20A-EWP**, **E-1600-20-IP-EWP**, **E-1600-30A-EWP** and **E-1600-30-IP-EWP** emergency phones, as well as the **W-1000-EWP** and **W-3000-EWP** handsfree doorboxes. The **VE-6x7** is designed to be used with the **K-1700-3-EWP** and **K-1705-EWP** entry phones and the **VE-5x10** is designed to be used with the **K-1900-7-EWP** and the **K-1900-8-EWP** vandal resistant phones.

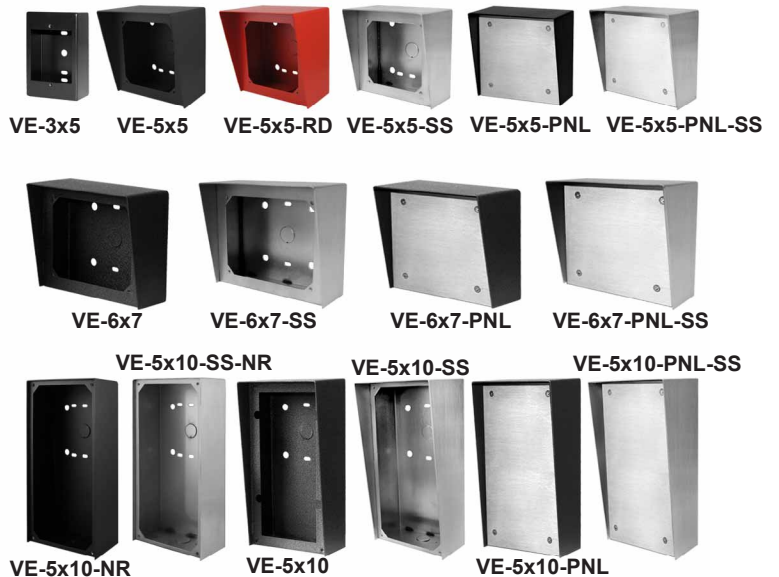
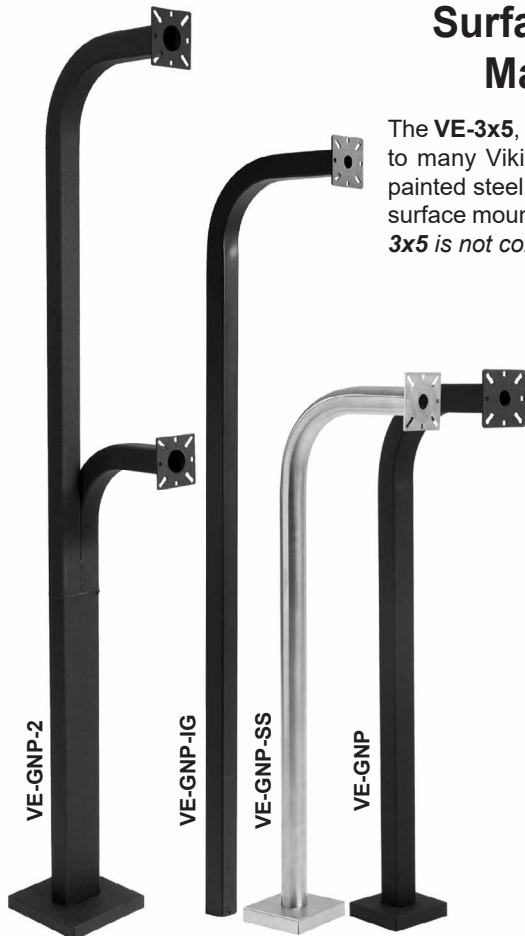

The **VE-GNP** gooseneck pedestals are designed to be used with the **VE-5x5**, **VE-6x7** and **VE-5x10** backboxes and are ideal for drive up communications.

Note: The VE-3x5 is not compatible with the VE-GNP pedestals. The **VE-PNL**'s are **VE-Series** backboxes with a blank aluminum panel. The user can customize the clear-coated aluminum panel to mount an **PRX-1** card reader, **PRX-2** keypad or switch. The kits come complete with box, gasket, panel and screws. Model numbers that end with “SS” are stainless steel version. **Note: The use of magnets to mount the VE-Series enclosure to a metal surface can affect the operation of the enclosed product.**

Viking Area of Refuge Signs Designed to Comply with IBC, ADA, NFPA and ICC Requirements



ARS-TB100

Tactile Blue Braille and raised letter sign to be placed next to the Area Of Refuge (stairwell exit) door.



ARS-IB100

Instructional Blue Braille and Raised letter sign to be placed next to the Area of Refuge emergency phone (E-1600A-IP, etc.)



ARS-DLB100



ARS-DRB100

Directional Blue signs with left or right arrow to be placed next to exit doors without Area Of Refuge.

- **ARS-TB100:** 6" wide x 9" tall Tactile Sign with 0.031" raised white letters and accessibility symbol, California compliant Contrated Grade 2 Braille. Blue PMS 300 Acrylic with non-glare finish, 0.032" thick double sided foam included.
- **ARS-IB100:** 6" wide x 7.5" tall Instructional sign with 0.031" raised white "Push For Help" letters and ingraved white text, California compliant Contrated Grade 2 Braille. Blue PMS 294 ABS with non-glare finish, 0.032" thick double sided foam included.

- **ARS-DLB100** (left arrow) and **ARS-DRB100** (right arrow): 12" wide x 4" tall Directional sign with ingraved white text, Blue PMS 294 ABS with non-glare finish, 0.032" thick double sided foam included.
- **VE-ARSW:** Area of Refuge surface mount command center cabinet. Lockable for mounting "Two-Way Communications System" phone in low rise (less than 60 ft tall) buildings. .

The **ARS Series** Area of Refuge Signs are designed comply with IBC 1007,1011, ADA 4.3.11, NFPA 22, 101 and ICC 703 code requirements. The Instructional, Tactile and Directional signs are made from Acrylic or durable ABS plastic and are designed to adhere to the wall with the provided double sided foam tape.

Emergency Phone Panic Button Kit (for use with Viking Emergency Phones)

The **PB-1** Panic Button Kit connects to a Viking **1600A** or **1600-IP Series** Emergency Phone to provide a one-way talk path to the pre-programmed number when used.

The **PB-1** will activate the **1600A** or **1600-IP Series** Emergency Phone and allows the called party to light a red LED to indicate that the call is connected. The called party will be able to hear the installation site, but the site will not be able to hear the called party. This makes it a very effective security measure, as there is no other indication that the site is being monitored.

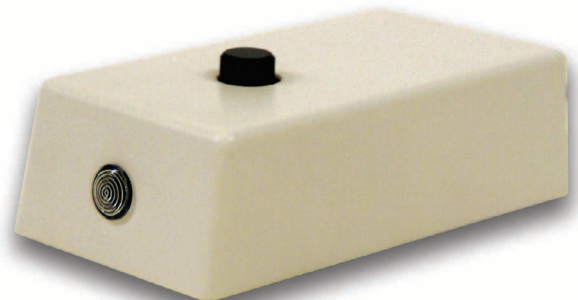

Warranty

IF YOU HAVE A PROBLEM WITH A VIKING PRODUCT, CONTACT VIKING TECHNICAL SUPPORT: 715-386-8666

Our Technical Support Department is available for assistance Monday through Friday 8:00am to 5:00pm central time. Before you call, please:

1. Know the model number, the serial number and what software version you have (see serial label).
2. Have the Product Manual in front of you.
3. It is best if you are on site.

RETURNING PRODUCT FOR REPAIR

The following procedure is for equipment that needs repair:

1. Customer must contact Viking's Technical Support Department at 715-386-8666 to obtain a Return Authorization (RA) number. The customer MUST have a complete description of the problem, with all pertinent information regarding the defect, such as options set, conditions, symptoms, methods to duplicate problem, frequency of failure, etc.
2. Packing: Return equipment in original box or in proper packing so that damage will not occur while in transit. The original product boxes are not designed for shipping - an overpack box is required to prevent damage in transit. Static sensitive equipment such as a circuit board should be in an anti-static bag, sandwiched between foam and individually boxed. All equipment should be wrapped to avoid packing material lodging in or sticking to the equipment. Include ALL parts of the equipment. C.O.D. or freight collect shipments cannot be accepted. Ship cartons prepaid to: **VIKING ELECTRONICS
1531 INDUSTRIAL STREET
HUDSON, WI 54016**
3. Return shipping address: Be sure to include your return shipping address inside the box. We cannot ship to a PO Box.
4. RA number on carton: In large printing, write the RA number on the outside of each carton being returned.

RETURNING PRODUCT FOR EXCHANGE

The following procedure is for equipment that has failed out-of-box (within 10 days of purchase):

1. Customer must contact Viking's Technical Support at 715-386-8666 to determine possible causes for the problem. The customer MUST be able to step through recommended tests for diagnosis.
2. If the Technical Support Product Specialist determines that the equipment is defective based on the customer's input and troubleshooting, a Return Authorization (RA) number will be issued. This number is valid for fourteen (14) calendar days from the date of issue.
3. After obtaining the RA number, return the approved equipment to your distributor. Please reference the RA number on the paperwork being shipped back with the unit(s), and also the outside of the shipping box. The original product boxes are not designed for shipping - an overpack box is required to prevent damage in transit. Once your distributor receives the package, they will replace the product over the counter at no charge. The distributor will then return the product to Viking using the same RA number.
4. **The distributor will NOT exchange this product without first obtaining the RA number from you. If you haven't followed the steps listed in 1, 2 and 3, be aware that you will have to pay a restocking charge.**

TWO YEAR LIMITED WARRANTY

Viking warrants its products to be free from defects in the workmanship or materials, under normal use and service, for a period of two years from the date of purchase from any authorized Viking distributor. If at any time during the warranty period, the product is deemed defective or malfunctions, return the product to Viking Electronics, Inc., 1531 Industrial Street, Hudson, WI., 54016. Customer must contact Viking's Technical Support Department at 715-386-8666 to obtain a Return Authorization (R.A.) number.

This warranty does not cover any damage to the product due to lightning, over voltage, under age, accident, misuse, abuse, negligence or any damage caused by use of the product by the purchaser or others. This warranty does not cover non-EWP products that have been exposed to wet or corrosive environments. This warranty does not cover stainless steel surfaces that have not been properly maintained.

NO OTHER WARRANTIES. VIKING MAKES NO WARRANTIES RELATING TO ITS PRODUCTS OTHER THAN AS DESCRIBED ABOVE AND DISCLAIMS ANY EXPRESS OR IMPLIED WARRANTIES OR MERCHANTABILITY OR FITNESS FOR ANY PARTICULAR PURPOSE.

EXCLUSION OF CONSEQUENTIAL DAMAGES. VIKING SHALL NOT, UNDER ANY CIRCUMSTANCES, BE LIABLE TO PURCHASER, OR ANY OTHER PARTY, FOR CONSEQUENTIAL, INCIDENTAL, SPECIAL OR EXEMPLARY DAMAGES ARISING OUT OF OR RELATED TO THE SALE OR USE OF THE PRODUCT SOLD HEREUNDER.

EXCLUSIVE REMEDY AND LIMITATION OF LIABILITY. WHETHER IN AN ACTION BASED ON CONTRACT, TORT (INCLUDING NEGLIGENCE OR STRICT LIABILITY) OR ANY OTHER LEGAL THEORY, ANY LIABILITY OF VIKING SHALL BE LIMITED TO REPAIR OR REPLACEMENT OF THE PRODUCT, OR AT VIKING'S OPTION, REFUND OF THE PURCHASE PRICE AS THE EXCLUSIVE REMEDY AND ANY LIABILITY OF VIKING SHALL BE SO LIMITED.

IT IS EXPRESSLY UNDERSTOOD AND AGREED THAT EACH AND EVERY PROVISION OF THIS AGREEMENT WHICH PROVIDES FOR DISCLAIMER OF WARRANTIES, EXCLUSION OF CONSEQUENTIAL DAMAGES, AND EXCLUSIVE REMEDY AND LIMITATION OF LIABILITY, ARE SEVERABLE FROM ANY OTHER PROVISION AND EACH PROVISION IS A SEPARABLE AND INDEPENDENT ELEMENT OF RISK ALLOCATION AND IS INTENDED TO BE ENFORCED AS SUCH.

If trouble is experienced with the **1600-IP Series** phone, for repair or warranty information, please contact:

Viking Electronics, Inc., 1531 Industrial Street, Hudson, WI 54016 Phone: 715-386-8666

WHEN PROGRAMMING EMERGENCY NUMBERS AND (OR) MAKING TEST CALLS TO EMERGENCY NUMBERS:

Remain on the line and briefly explain to the dispatcher the reason for the call. Perform such tests in off-peak hours, such as early morning or late evenings.

PART 15 LIMITATIONS

This equipment has been tested and found to comply with the limits for a Class A digital device, pursuant to Part 15 of the FCC Rules. These limits are designed to provide reasonable protection against harmful interference when the equipment is operated in a commercial environment. This equipment generates, uses, and can radiate radio frequency energy and, if not installed and used in accordance with the instruction manual, may cause harmful interference to radio communications. Operation of this equipment in a residential area is likely to cause harmful interference in which case the user will be required to correct the interference at his own expense.

CANADA

This class A digital apparatus complies with Canadian ICES-003. Cet appareil numérique de la classe A est conforme a la norme NMB-003 du Canada.

Product Support: 715-386-8666

Due to the dynamic nature of the product design, the information contained in this document is subject to change without notice. Viking Electronics, and its affiliates and/or subsidiaries assume no responsibility for errors and omissions contained in this information. Revisions of this document or new editions of it may be issued to incorporate such changes.